



*An Online CPD Course  
brought to you by  
CEDengineering.ca*

# Concrete Removal, Repair and Maintenance

Course No: C06-002  
Credit: 6 PDH

---

Gilbert Gedeon, P.E.

---



Continuing Education and Development, Inc.

P: (877) 322-5800  
[info@cedengineering.ca](mailto:info@cedengineering.ca)

*This course was adapted from the United States Army Corps of Engineers (USACE), Publication No. EM 110-2-2002, "Evaluation and Repair of Concrete Structures", which is in the public domain.*

## Chapter 5 Concrete Removal and Preparation for Repair

### 5-1. Introduction

Most repair projects involve removal of distressed or deteriorated concrete. This chapter discusses removal of concrete, preparation of concrete surfaces for further work such as overlays, preparation and replacement of reinforcing steel that has been exposed during concrete removal, and anchorage systems. Regardless of the cost or complexity of the repair method or of the material selected, the care with which deteriorated concrete is removed and with which a concrete surface is prepared will often determine whether a repair project will be successful.

### 5-2. Concrete Removal

*a. Alternatives.* Repair techniques requiring no concrete removal should be considered for situations where the deteriorated and damaged concrete does not threaten the integrity of the member or structure. The cost of concrete removal was saved in the rehabilitation of the tops of lock walls at Dashields Locks, U.S. Army Engineer District, Pittsburgh, by placement of an unbonded concrete overlay without removal of the deteriorated concrete. Similarly, the cost of concrete removal was saved by installation of precast concrete panels over deteriorated concrete on the backside of river walls at Lockport Lock in the U.S. Army Engineer District, Rock Island, and Troy Lock in the U.S. Army Engineer District, New York.

*b. Environment.* An evaluation to assess the impact of concrete removal debris entering a river, stream, or waterway is required before a contract is awarded. The impact varies from project to project and depends to a great extent on the size and environmental condition of the waterway and on the quantity of removal debris entering the waterway. The coarse-aggregate portion of the debris is sometimes a natural river gravel that is being returned to its place of origin and therefore its impact on the waterway is generally considered negligible. When debris fragments are of sufficient size, debris can be placed in open water to construct a fish attractor reef as an means of disposal. Recycling of concrete debris should be considered as an alternative to landfill disposal.

*c. Contract work.* If work is to be contracted, the information describing the condition and properties of the

concrete must be made available at the time of invitation for bids to reduce the potential for claims by the contractor of “differing site conditions.” Information provided may include type and range of deterioration, nominal maximum size and type of coarse aggregate, percentage of reinforcing steel, compressive and splitting-tensile strengths of concrete, and other pertinent information. When uncertainties exist regarding the condition of the concrete or the performance of the removal technique(s), an onsite demonstration should be implemented to test production rates and ensure acceptable results before work is begun.

*d. General considerations.* Several general considerations should be kept in mind in the selection of a concrete removal method:

(1) Usually, a repair or rehabilitation project will involve removal of deteriorated concrete. However, for many maintenance and repair projects, concrete is removed to a fixed depth to ensure that the bulk of deteriorated concrete is removed or to accommodate a specific repair technique. For some projects, this requirement would cause a significant amount of sound concrete to be removed and, thereby, a change in removal method(s), since some methods are more cost effective for sound concrete than others.

(2) Selected concrete removal methods should be safe and economical and should have as little effect as possible on concrete remaining in place. Selection of a proper removal method may have a significant effect on the length of time that a structure must be out of service. Some methods permit a significant portion of the work to be accomplished without removing the structure from service. For example, drilling of boreholes in a lock wall in conjunction with removal of concrete by blasting may be done while the lock is operational.

(3) The same removal method may not be suited for all portions of a given structure. The most appropriate method for each portion of the structure should be selected and specified.

(4) More than one removal method may be required for a particular area. For example, a presplitting method may be used to fracture and weaken the concrete to be removed, while an impacting method is used to complete the removal for the same location.

(5) In some instances, a combination of removal methods may be used to limit damage to concrete that is not being removed. For example, a cutting method may

be used to delineate an area in which an impacting method is to be used as the primary means of removal.

(6) Field tests of various removal methods are very well suited for demonstration projects done during the design phase of a major repair or rehabilitation project.

(7) The cost of removal and repair should be compared to the cost of total demolition and replacement of the member or structure if the damage is extensive.

(8) Care should be taken to avoid embedded items such as electrical conduits and gate anchorage's. Dimensions and locations of embedded items documented in the as-built drawings should not be taken for granted.

*e. Classification of concrete removal methods.* Removal methods may be categorized by the way in which the process acts on the concrete. These categories are blasting, crushing, cutting, impacting, milling, and presplitting. Table 5-1 provides a general description of these categories and lists the specific removal methods within each category. Table 5-2 provides a summary of information on each method. These methods are discussed in detail in the following. See Campbell (1982) for additional information.

*f. Blasting methods.* Blasting methods employ rapidly expanding gas confined within a series of boreholes to produce controlled fracture and removal of concrete (Figure-5-1). Explosive blasting, the only blasting method commercially available in the United States, is applicable for concrete removal from mass concrete structures where 250 mm (10 in.) or more of face is to be removed and the volume of removal is significant. Explosive blasting is considered to be the most expedient and, in many cases, the most cost-effective means of removal from mass concrete structures. Its primary disadvantage is its potential for damage to the remaining concrete and adjacent structures. Blasting plans typically include drilling holes along removal boundary and employing controlled and sequential blasting methods for the removal. A commonly employed, controlled blasting technique, smooth blasting, uses detonating cord to distribute the blast energy throughout the hole, thereby, avoiding energy concentrations that might damage the concrete that remains. Cushion blasting, a more protective but less used control, is the same as smooth blasting except wet sand is used to fill holes and cushion against the blast effect. The use of saw cuts along removal perimeters is recommended to reduce overbreakage. For removal of vertical faces, a full-depth cut is recommended along the bottom boundary. Sequential blasting techniques allow

more delays to be employed per firing. They are recommended for optimizing the amount of explosive detonated per firing while maintaining air-blast pressures, ground vibrations, and fly rock at acceptable levels. When uncertainties regarding the blast plan exist, a pilot test program is recommended to evaluate parameters and ensure acceptable results. Because of dangers inherent in handling and using explosives, all phases of the blasting project should be performed and monitored for compliance with EM 385-1-1.

*g. Crushing methods.* Crushing methods employ hydraulically powered jaws to crush and remove the concrete.

(1) Boom-mounted mechanical crushers. Boom-mounted crushers (Figure 5-2) are applicable for removing concrete from decks, walls, columns, and other concrete members where the shearing plane depth is 1.8 m (6 ft) or less. This method is typically more applicable for total demolition of a member(s) than for partial removal for rehabilitation or repair. Pulverizing jaw attachments that crush and debond the concrete from the reinforcing steel to facilitate their separation for recycling are available. The major limitations are that the removal boundary must be saw cut to reduce overbreakage, crushing must be started from a free edge or hole made by hand-held breakers or other means, and the exposed reinforcing is damaged beyond reuse. Care must be taken to avoid damaging members that are to support the repair.

(2) Portable mechanical crushers. Portable crushers are applicable for removing concrete from decks, walls, columns, and other concrete members where the shearing plane depth is 300 mm (12 in.) or less. The crusher weighs approximately 45 kg (100 lb) and requires two men to handle. The major limitations are that the removal boundary must be saw cut to reduce overbreakage, crushing must be started from a free edge or hole made by hand-held breakers or other means, and the exposed reinforcing is damaged beyond reuse.

*h. Cutting methods.* Cutting methods employ full depth perimeter cuts to disjoint concrete for removal as a unit(s). The maximum size of the unit(s) is determined by the load carrying capacities of available lifting and transporting equipment. Cutting methods include abrasive water jets, diamond saws, stitch drilling, and thermal tools.

(1) Abrasive-water-jet cutting. Water-jet systems that include abrasives are applicable for making cutouts through slabs, walls, and other concrete members where

**Table 5-1  
A General Classification of Concrete Removal Methods Applicable for Concrete Repair**

Category	Description	Specific Methods
Blasting	Blasting methods employ rapidly expanding gas confined within a series of boreholes to produce controlled fracture and removal of concrete	Explosive blasting
Crushing	Crushing methods employ hydraulically powered jaws to crush and remove the concrete	Mechanical crushing, boom-mounted Mechanical crushing, portable
Cutting	Cutting methods employ full-depth perimeter cuts to disjoint concrete for removal as a unit or units	Abrasive-water-jet cutting Diamond-blade cutting Diamond-wire cutting Sitch drilling Thermal cutting
Impacting	Impacting methods employ repeated striking of the surface with a mass to fracture and spall the concrete	Mechanical impacting, hand-held Mechanical impacting, boom-mounted Mechanical impacting, spring-action
Milling	Milling methods generally employ abrasion or cavitation-erosion techniques to remove concrete from surfaces	Hydromilling Rotary head milling
Presplitting	Presplitting methods employ wedging forces in a designed pattern of boreholes to produce a controlled cracking of the concrete to facilitate removal of concrete by other means	Presplitting, chemical-expansive agents Presplitting, piston-jack splitter Presplitting, plug-and-feather splitter

**Table 5-2  
Selection Features and Considerations for Concrete Removal Methods**

Category	Method	Features	Considerations
Blasting	Explosive blasting	Method applicable for removal from mass concrete structures	Requires highly skilled personnel for design and execution of blasting plan
		Method is most expedient and, in many cases, the most cost-effective means of removing large volumes where 250 mm (10 in.) or more of face is to be removed  Produces reasonably small size debris that is easily handled	Stringent safety regulations must be complied with regard to the transportation, storage, and use of explosives because of their inherent dangers  Sequential blasting techniques must be employed to reduce peak blast energies and, thereby, limit damage to surrounding property resulting from air-blast pressure, ground vibration, and fly rock
Crushing	Mechanical crushing, boom-mounted	Method applicable for removing concrete from decks, walls, columns, and other concrete members where shearing plane depth is 1.8 m (6 ft) or less	Control blasting techniques should be employed to limit damage to concrete that remains
		Boom allows removal from vertical and overhead members	Method is more applicable for total demolition of a concrete member than for removal to rehabilitate or repair
		Steel reinforcing can be cut	Boundaries must be saw cut to limit overbreakage
		Limited noise and vibration is produced	Removal must be started from a free edge or a hole cut in member
		Pulverizing jaw attachment can debond the concrete from the steel reinforcement for purpose of recycling both	Exposed reinforcing steel is damaged beyond reuse
		Method produces relatively small debris that is easily handled	Production rates vary depending on condition of concrete and amount of reinforcement
		Method applicable for removal from decks, walls, and other members where shearing plane depth is 300 mm (12 in.) or less	Requires two men to handle (weighs approximately 45 kg (100 lb))
		Method can be used to remove concrete in areas of limited work space	Reinforcing steel is damaged beyond reuse
			Crushing must be started from a free edge or a hole cut in member
			Boundaries must be saw cut to limit overbreakage

(Sheet 1 of 8)

**Table 5-2 (Continued)**

Category	Method	Features	Considerations
Cutting	Abrasive-water-jet cutting	<p>Limited noise and vibration is produced</p> <p>Produces small size debris that is easily handled</p> <p>Method applicable for making cutouts through slabs, walls, and other concrete members where access to only one face is feasible and depth of cut is 500 mm (20 in.) or less</p> <p>Abrasives enable jet to cut steel reinforcing and hard aggregates</p> <p>Irregular and curved cutouts can be made</p> <p>Cutouts can be made without overcutting corners</p> <p>Cuts can be made flush with adjoining members</p> <p>No heat, vibration, or dust is produced</p> <p>Handling of debris is more efficient as bulk of concrete is removed as units</p>	<p>Production rates are low</p> <p>Cutting is typically slower and more costly than diamond-blade sawing</p> <p>Controlling flow of waste water may be required</p> <p>Personnel must wear hearing protection because of the high levels of noise produced</p> <p>Additional safety precautions are required because of high water pressures (200 - 340 MPa (30,000 - 50,000 psi)) produced by system</p>
	Diamond-blade cutting	<p>Method applicable for making cutouts through slabs, walls, and other concrete members where access to only one face is feasible and depth of cut is 600 mm (24 in.) or less</p> <p>Precision cuts can be made</p> <p>No dust or vibration is produced</p> <p>Handling of debris is more efficient as bulk of concrete is removed as units</p>	<p>Selection of the type diamonds and metal bond used in blade segments is based on the type (hardness) and percent of coarse aggregate and on the percent of steel reinforcing in cut</p> <p>The higher the percent of steel reinforcement in cuts, the slower and more costly the cutting</p> <p>The harder the aggregate, the slower and more costly the cutting</p> <p>Controlling flow of waste water may be required</p> <p>Special blades with flush-cut arbors are required to make cuts flush with adjoining members</p>

**Table 5-2 (Continued)**

Category	Method	Features	Considerations
	Diamond-wire cutting	<p>Method applicable for making cutouts through concrete where depth of cut is greater than can be economically cut with the diamond-blade saw</p> <p>Cuts can be made through mass concrete and in areas of difficult access</p> <p>Overcutting of corner can be avoided if cut started from drilled hole at corner</p> <p>No dust or vibration is produced</p> <p>Handling of debris is more efficient as bulk of concrete is removed as units</p>	<p>The wire saw is a specialty tool that for many jobs will not be as cost effective as other techniques, such as blasting, impacting, and presplitting.</p> <p>Selection of type diamonds and metal bond used in beads is based on type (hardness) and percent of coarse aggregate and percent of steel reinforcing in cut</p> <p>The higher the percent of steel reinforcement in cuts, the slower and more costly the cutting</p> <p>The harder the aggregate, the slower and more costly the cutting</p> <p>Beads with embedded diamonds last longer, but are more expensive than beads with electroplated diamonds (single layer)</p> <p>Wires with beads having embedded diamonds should be of sufficient length to complete cut as replacement will not fit into cut (wear reduces wire diameter and, thereby, cut opening as cutting proceeds).</p>
	Stitch drilling	<p>Method applicable for making cutouts through concrete members where access to only one face is feasible and depth of cut is greater than can be economically cut by diamond-blade saw</p> <p>Handling of debris is more efficient as bulk of concrete is removed as units</p>	<p>Deep cutouts that are formed by three or more boundary cuts may require tapering to avoid binding during removal</p> <p>Controlling flow of waste water may be required</p> <p>Rotary-percussion drilling is significantly more expedient and economical than diamond-core for nonreinforced concrete</p> <p>Diamond-core drilling is more applicable than rotary-percussion drilling for reinforced concrete</p> <p>The greater the percentage of steel reinforcement contained within a cut, the slower and more costly is the cutting</p> <p>Depth of cuts is dependent on accuracy of drilling equipment in maintaining overlap between holes with depth and on the diameter of boreholes drilled</p> <p>The deeper the cut, the greater borehole diameter required to maintain overlap between adjacent holes and the greater the cost</p> <p>Uncut portions between adjacent boreholes will prevent removal</p>

(Sheet 3 of 8)



Table 5-2 (Continued)

Category	Method	Features	Considerations
			Concrete toughness for percussion drilling and aggregate hardness for diamond coring will affect cutting rate and cost
			Personnel must wear hearing protection because of the high levels of noise produced
	Thermal cutting	<p>Method applicable for making cutouts through heavily reinforced decks, beams, walls, and other reinforced members where site conditions allow efficient flow of molten concrete from cuts</p> <p>Method is an effective means of cutting prestressed members</p> <p>Irregular shapes can be cut</p> <p>Minimal vibration and dust produced</p> <p>Handling of debris is more efficient as bulk of concrete is removed as units</p>	<p>Method is of limited commercial availability and is costly</p> <p>Remaining concrete has thermal damage with more extensive damage occurring around steel reinforcement</p> <p>Noise, smoke, and fumes are produced</p> <p>Personnel must be protected from heat and hot flying rock produced by cutting operation</p> <p>Additional safety precautions are required because of hazards associated with storage, handling, and use of compressed and flammable gases</p>
Impacting	Mechanical impacting, boom-mounted breaker	<p>Method is applicable for both full and partial depth removals where required production rates are greater than can be economically achieved by the use of hand-held breakers</p> <p>Boom allows concrete to be removed from vertical and overhead members</p> <p>Boom-mounted breakers are widely available commercially</p> <p>Method produces easily handled debris</p>	<p>The blow energy delivered to the concrete should be limited to protect the structure being repaired and surrounding structures from damage resulting from the high cyclic energy generated</p> <p>Performance is function of concrete soundness and toughness</p> <p>Productivity is significantly reduced when boom is operated from top of wall because of the operator's limited view of the removal operation</p> <p>Care must be taken to avoid damage to supporting members</p> <p>Concrete that remains may be damaged (microcracking) along with reinforcing steel</p> <p>Saw cuts at boundaries should be employed to reduce the occurrence of feathered edges</p> <p>Dust is produced</p> <p>Personnel must wear hearing protection because of the high levels of noise produced</p>

Table 5-2 (Continued)

Category	Method	Features	Considerations
	Mechanical impacting, hand-held breaker	<p>Method is applicable for work involving limited volumes of concrete removal and for removal in areas of limited access</p> <p>Hand-held breakers are widely available commercially</p> <p>Breakers can be operated by unskilled labor</p> <p>Method produces relatively small debris that is easily handled</p>	<p>Hand-held breakers are generally not applicable for large volumes of removal, except where blow energy must be limited</p> <p>Performance is function of concrete soundness and toughness</p> <p>Significant loss in productivity occurs when breaking action is other than downward</p> <p>Removal boundaries will likely require 25-mm (1-in.) deep or greater saw cut to reduce the occurrence of feathered edges</p> <p>Concrete that remains may be damaged (microcracking)</p> <p>Size of breakers for bridge decks is typically limited to 14-kg (30-lb) class for removal above reinforcement and 7-kg (15-lb) class from around reinforcement</p> <p>Dust is produced</p> <p>Personnel must wear hearing protection because of the high levels of noise produced</p> <p>Method is more applicable for total demolition of a concrete member than for removal to rehabilitate or repair</p> <p>The blow energy delivered to the concrete should be limited to protect the structure being repaired and surrounding structures from damage resulting from the high cyclic energy generated</p> <p>Care must be taken to avoid damage to supporting members</p> <p>Performance is function of concrete soundness and toughness</p> <p>Concrete that remains may be damaged (microcracking) along with reinforcing steel</p> <p>Saw cuts at boundaries should be employed to reduce the occurrence of feathered edges</p> <p>Method is costly</p> <p>Productivity is significantly reduced when sound concrete is being removed</p>
	Mechanical impacting, spring-action hammer	<p>Method is applicable for breaking concrete pavement, decks, walls, and other thin members where production rates required are greater than can be economically achieved by the use of hand-held breakers</p> <p>For decks, hammer can completely punch through slab with each blow leaving only the reinforcing steel</p> <p>Method produces easily handled debris</p>	
Milling	Hydromilling (Also known as hydrodemolition and water-jet blasting)	<p>Method is applicable for removal of deteriorated concrete from surfaces of decks and walls where removal depth is 150 mm (6 in.) or less</p>	

(Sheet 5 of 8)

**Table 5-2 (Continued)**

Category	Method	Features	Considerations
		<p>Method does not damage the concrete that remains</p> <p>Steel reinforcing is left undamaged for reuse</p> <p>Method produces easily handled, aggregate-size debris</p>	<p>Removal profile will vary with changes in depth of deterioration</p> <p>Holes through member (blowouts) are a common occurrence when removal is near full depth of member</p> <p>Repair of blowouts requires additional material and form work, thereby, increasing repair time and cost</p>
			<p>Method requires large source of potable water (the water demand for some units exceeds 4,000 L/hr (1,000 gal/hr))</p>
			<p>Laitence coating that is deposited on remaining surfaces during removal should be washed from surface before coating dries</p>
			<p>Flow of waste water may have to be controlled</p>
			<p>An environmental impact statement will be required if waste water is to enter a waterway</p>
			<p>Personnel must wear hearing protection because of the high level of noise produced</p>
			<p>Fly rock is produced</p>
			<p>Additional safety requirements are required because of the high pressures (100 - 300-MPa (16,000 - 40,000-psi) range) produced by the system</p>
			<p>Removal is limited to concrete outside structural steel reinforcement</p>
			<p>Significant loss of productivity occurs in sound concrete</p>
			<p>Productivity is significantly reduced when boom is operated from top of wall as operator's view of cutting is very limited</p>
			<p>Concrete that remains may be damaged (microcracking)</p>
		<p>Boom allows removal from vertical and overhead surfaces</p>	<p>Skid loader units typically mill a more uniform removal profile than other rotary-head and water-jet units</p>

(Sheet 6 of 8)

Table 5-2 (Continued)

Category	Method	Features	Considerations
Presplitting	Chemical presplitting, expansive agents	<p>Concrete containing wire mesh can be cut without significant losses in productivity</p> <p>Method produces relatively small debris that is easily handled</p> <p>Method is applicable for presplitting concrete members where depth of boreholes is 10 times borehole diameter or greater</p> <p>Expansive products can be used to produce vertical presplitting planes of significant depth</p> <p>Some products form a clay-type material when mixed with water that allows the material to be packed into horizontal holes</p> <p>No vibration, noise, or flying rock is produced other than that produced by the drilling of boreholes and the secondary breakage method</p>	<p>Noise, vibration, and dust are produced</p> <p>Personnel must be restricted from presplitting area during early hours of product hydration as material has the potential to blow out of boreholes and cause injury</p> <p>Presplitting with expansive agents is typically costly</p> <p>Expansive products that are prills or become slurries when water is added are best used in gravity-filled, vertical, or near-vertical holes. A liner may be required to contain the expansive material in holes drilled into concrete with extensive cracks</p> <p>Products are limited to a specific temperature range</p> <p>Rotary-head milling or mechanical-impacting methods will be required to complete removal</p> <p>Development of presplitting plane is significantly decreased by presence of reinforcing steel normal to plane</p> <p>Loss of control of presplitting plane can result if boreholes are too far apart or holes are located in severely deteriorated concrete</p>
	Mechanical presplitting, piston-jack splitter	<p>Method is applicable for presplitting more massive concrete structures where 250 mm (10 in.) or more of face is to be removed and presplitting requires boreholes of a depth greater than can be used by plug-and-feather splitters</p> <p>Splitter can be reinserted into boreholes to continue removal for full depth of holes</p> <p>Splitter can be used in areas of difficult access</p>	<p>Large-diameter (90-mm (3-1/2-in.)) boreholes are required that increase cost</p> <p>Splitters are typically used in pairs to control presplitting plane</p> <p>Hand-held breakers and pry bars are typically required to complete removal</p> <p>Development of presplitting plane is significantly decreased by presence of reinforcing steel normal to presplit plane</p> <p>Loss of control of presplitting plane can result if boreholes are too far apart or holes are located in severely deteriorated concrete</p>

**Table 5-2 (Concluded)**

Category	Method	Features	Considerations
		No vibration, noise, or flying rock is produced other than that produced by the drilling of boreholes and the secondary breakage method	Availability of splitters is limited in the U.S.
	Mechanical presplitting, plug-and-feather splitter	Method applicable for presplitting slabs, walls, and other concrete members where presplitting depth is 4 ft or less  Method typically less costly than cutting methods  Initiation of direction of presplitting can be controlled by orientation of plug and feathers  Splitters can be used in areas of limited access  Limited skills required by operator	Splitter can not be reinserted into boreholes to continue presplitting after presplit section has been removed, as the body of the tool is wider than the borehole  Development of presplitting plane in direction of borehole depth is limited  Development of presplitting plane is significantly decreased by presences of reinforcing steel normal to plane  Secondary means of breakage will typically be required to complete removal  Loss of control of presplitting plane can result if boreholes are too far apart or holes are located in severely deteriorated concrete
		No vibration, noise, or flying rock is produced other than that produced by the drilling of boreholes and the secondary breakage method	

(Sheet 8 of 8)

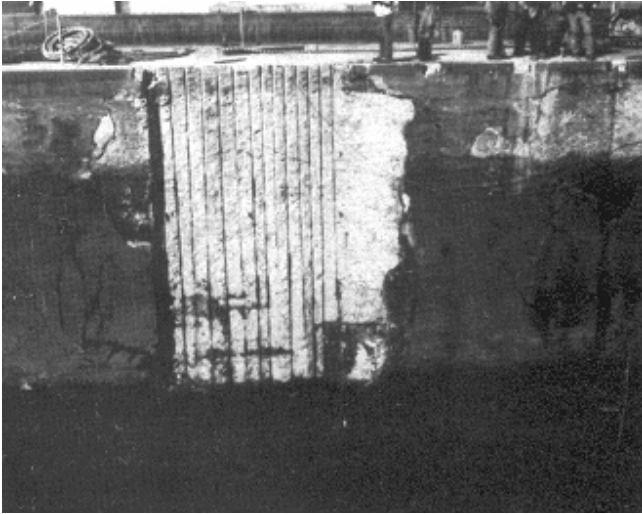

**Figure 5-1. Surface removal of deteriorated concrete by explosive blasting**



**Figure 5-2. Boom-mounted concrete crusher**

access to only one face is feasible and depth of cut is 500 mm (20 in.) or less. The abrasives enable the jet to cut steel reinforcing and hard aggregates. One major limitation of abrasive-water-jet cutting is that it is typically slower and more costly than diamond-blade sawing. Personnel must wear hearing protection because of the high levels of noise produced. Additional safety precautions are required because of high water pressures (200 to 340 MPa (30,000 to 50,000 psi)) produced by the system. Controlling flow of waste water may be required.

(2) Diamond-blade cutting. Diamond-blade cutting (Figure 5-3) is applicable for making cutouts through slabs, walls, and other concrete members where access to only one face is feasible and depth of cut is 600 mm (24 in.) or less. Blade selection is a function of the type (hardness) and percent of coarse aggregate and on the percent of steel reinforcing. The harder the coarse aggregate and the higher the percentage of steel reinforcement in the cut, the slower and more costly the cutting. Diamond-blade cutting is also applicable for making cuts along removal boundaries to reduce feathered edges in support of other methods.

(3) Diamond-wire cutting. Diamond-wire cutting (Figure 5-4) is applicable for making cutouts through concrete where the depth of cut is greater than can be economically cut with a diamond-blade saw. Cuts can be made through mass concrete and in areas of difficult access. The cutting wire is a continuous loop of multi-strand wire cable strung with steel beads containing either embedded or electroplated diamonds. Beads with embedded diamonds last longer but are more expensive than beads with electroplated diamonds (single layer). Wires with beads having embedded diamonds should be of sufficient length to complete the cut as replacement wire will not fit into the cut (wear reduces wire diameter and, thereby, cut opening as cutting proceeds). The wire saw is a specialty tool that for many jobs will not be as



**Figure 5-3. Diamond-blade saw**

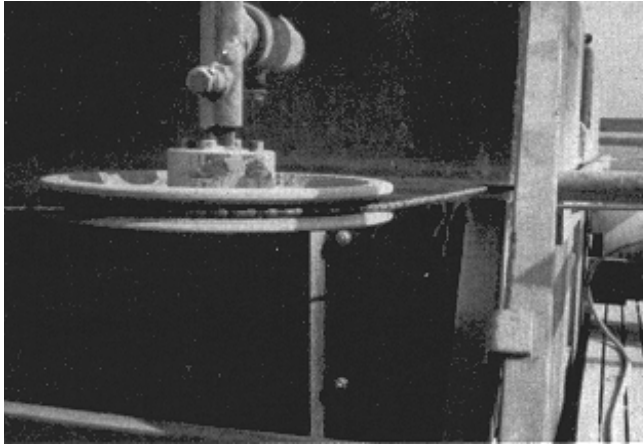
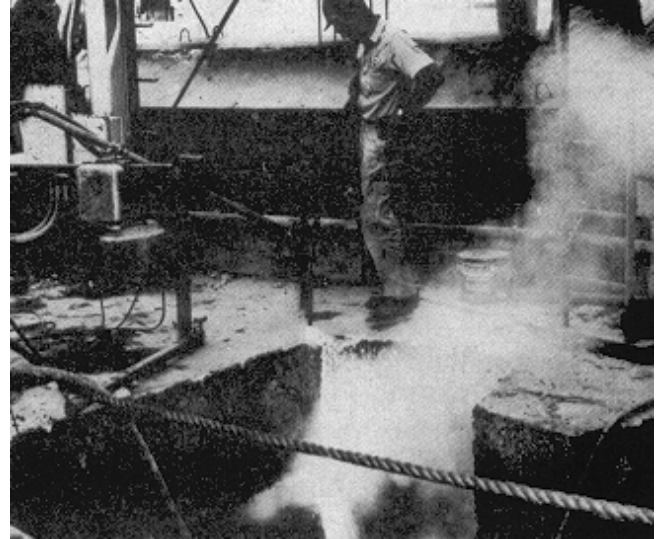

**Figure 5-4. Diamond-wire saw**

cost effective as other methods, such as blasting, impacting, and presplitting.

(4) *Stitch cutting.* Method applicable for making cutouts through concrete members where access to only one face is feasible and depth of cut is greater than can be economically cut by diamond-blade saw. Depth of cuts is dependent on the accuracy of drilling equipment in maintaining overlap between holes with depth and on the diameter of boreholes drilled. If overlap between holes is not maintained, uncut portions of concrete that will prevent removal remain between adjacent boreholes. If opposite faces of a member can be accessed, diamond-wire cutting will likely be more applicable. Concrete toughness for percussion drilling and aggregate hardness for diamond coring will affect the cutting rate and the cost.

(5) *Thermal cutting.* Thermal-cutting methods are applicable for making cutouts through heavily reinforced decks, beams, walls, and other reinforced members where site conditions allow efficient flow of molten concrete from cuts. Flame tools (Figure 5-5) are typically employed for cutting depths of 600 mm (24 in.) or less, and lances (Figure 5-6), for greater depths. Thermal cutting tools are of limited commercial availability and are costly to use. The concrete that remains has a layer of thermal damage with more extensive damage occurring around steel reinforcement. Personnel must be protected from heat and hot flying rock produced by the cutting operation. Additional safety precautions are required because of the hazards associated with the storage, handling, and use of compressed and flammable gases. The



**Figure 5-5. Powder torch**



**Figure 5-6. Thermal lance**

method is also applicable for the demolition of prestressed members.

*i. Impacting methods.* Impacting methods generally employ the repeated striking of a concrete surface with a mass to fracture and spall the concrete. Impact

methods are sometimes used in a manner similar to cutting methods to disjoint the concrete for removal as a unit(s) by breaking out concrete along the removal perimeter of thin members such as slabs, pavements, decks, and walls. Any reinforcing steel along the perimeter would have to be cut to complete the disjointment. Impacting methods include the boom-mounted and hand-held breakers and spring-action hammers.

(1) Boom-mounted breakers. Boom-mounted impact breakers are applicable for both full- and partial-depth removals where production rates required are greater than can be economically achieved by the use of hand-held breakers. The boom-mounted breakers are somewhat similar to the hand-held breakers except that they are considerably more massive. The tool is normally attached to the hydraulically operated arm of a backhoe or excavator (Figure 5-7) and can be operated by compressed air or hydraulic pressure. The reach of the hydraulic arm enables the tool to be used on walls at a considerable distance above or below the level of the machine. Boom-mounted breakers are a highly productive means of removing concrete. However, the blow energy delivered to the concrete should be limited to protect the structure being repaired and surrounding structures from damage resulting from the high cyclic energy generated. Saw cuts



Figure 5-7. Boom-mounted breaker

should be employed at removal boundaries to reduce the occurrence of feathered edges. The concrete that remains may be damaged (microcracking) along with the exposed reinforcing steel. Washing the concrete surface with a high-pressure (138 MPa (20,000 psi) minimum) water jet may remove some of the microfractured concrete.

(2) Spring-action hammers. Spring-action hammers (sometimes referred to as mechanical sledgehammers) are boom-mounted tools that are applicable for breaking concrete pavements, decks, walls, and other thin members where production rates required are greater than can be economically achieved with the use of hand-held breakers. Hammers are more applicable for total demolition of a concrete member than for removal to rehabilitate or repair. The arm of the hammer is hydraulically powered, and the impact head is spring powered. The spring is compressed by the downward movement of the arm of the backhoe or excavator and its energy released just prior to impact. There are truck units available that make it easier to move between projects. The operation of the hammer and advancement of the truck during removal are controlled from a cab at the rear of truck (Figure 5-8). The blow energy delivered to the concrete should be limited to protect the structure being repaired and surrounding structures from damage caused by the high cyclic energy generated. Saw cuts should be employed at removal boundaries to reduce the occurrence of feathered edges. The concrete that remains may be damaged (microcracking) along with the exposed reinforcing steel.

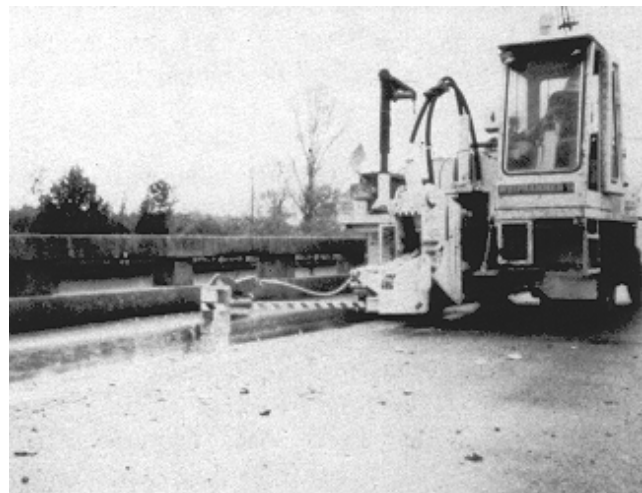

Figure 5-8. Spring-action hammer (mechanical sledgehammer)



(3) Hand-held impact breakers. Hand-held impact breakers (Figure 5-9) are applicable for work involving limited volumes of concrete removal and for removal in areas of limited access. Hand-held breakers are sometimes applicable for large volumes of removal where blow energy must be limited or the concrete is highly deteriorated. Breakers are also suitable for use in support of other means of removal. Hand-held breakers are powered by one of four means: compressed air, hydraulic pressure, self-contained gasoline engine, or self-contained electric motor.

*j. Milling.* Milling methods generally employ impact-abrasion or cavitation-erosion techniques to remove concrete from surfaces. Methods include hydromilling and rotary-head milling.

(1) Hydromilling. Hydromilling (also known as hydrodemolition and water-jet blasting) is applicable for removal of deteriorated concrete from surfaces of decks (Figure 5-10) and walls where removal depth is 150 mm (6 in.) or less. This method does not damage the concrete that remains and leaves the steel reinforcing undamaged for reuse in the replacement concrete. Its major limitations are that the method is costly, productivity is significantly reduced when sound concrete is being removed, and the removal profile varies with changes in depth of deterioration. Holes through members (blowouts) are a common occurrence when removal is near full depth of a member. This method requires a large source of potable water (the water demand for some units exceeds 4,000 L/hr (1,000 gal/hr)). An environmental impact statement is required if waste water is to enter a waterway. Personnel must wear hearing protection because of

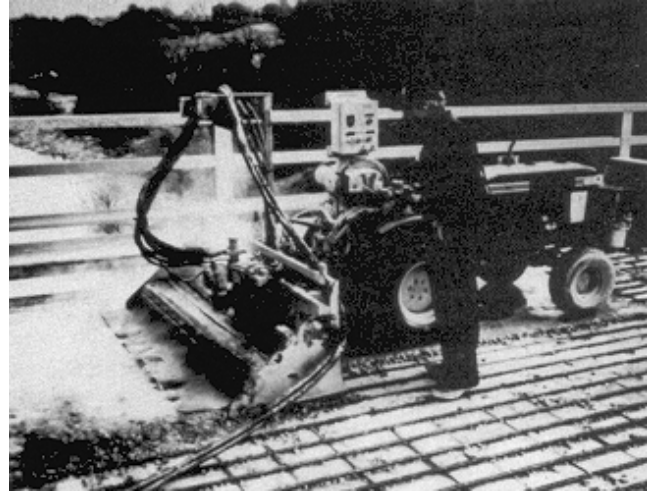

Figure 5-10. Hydromilling (water-jet blasting)

the high level of noise produced. Flying rock is produced. Laitence coating that is deposited on remaining surfaces during removal should be washed from the surfaces before the coating dries.

(2) Rotary-head milling. Method is applicable for removing deteriorated concrete from mass structures (Figure 5-11) and for removing deteriorated concrete cover from reinforced members such as pavements and decks where its contact with the reinforcement is unlikely. Removal is limited to concrete outside structural steel reinforcement. Significant loss of productivity occurs in sound concrete. For concrete having a compressive strength of 55 MPa (8,000 psi) or greater, rotary-head milling is not applicable. Concrete that remains may be



Figure 5-9. Hand-held breaker



Figure 5-11. Rotary-head milling

damaged (microcracking). Skid loader units typically mill a more uniform removal profile than other rotary-head and water-jet units.

*k. Presplitting.* Presplitting methods employ wedging forces in a designed pattern of boreholes to produce a controlled cracking of the concrete to facilitate removal of concrete by other means. The pattern, spacing, and depth of the boreholes affect the direction and extent of the presplitting planes. Presplitting methods include chemical-expansive agents and hydraulic splitters. Note: for all presplitting methods, the development of a presplitting plane is significantly decreased by the presence of reinforcing steel normal to the plane, and the loss of control of a presplitting plane can result if boreholes are too far apart or holes are located in severely deteriorated concrete.

(1) Chemical presplitting, expansive agents. The presplitting method that uses chemical-expansive agents (Figure 5-12) is applicable for removal from slabs, walls, and other concrete members where depth of boreholes is 10 times the borehole diameter or greater. It is especially applicable for situations requiring the development of vertical presplitting planes of significant depth. The main disadvantages of employing expansive agents are cost and application-temperature limitations. Personnel must be restricted from the presplitting area during early hours of product hydration as the material has the potential to blow out of boreholes and cause injury. Expansive products that are prills or become slurries when water is added are best used in gravity filled, vertical or near-vertical holes. Some products form a clay-type material when mixed with water that allows the material to be packed into

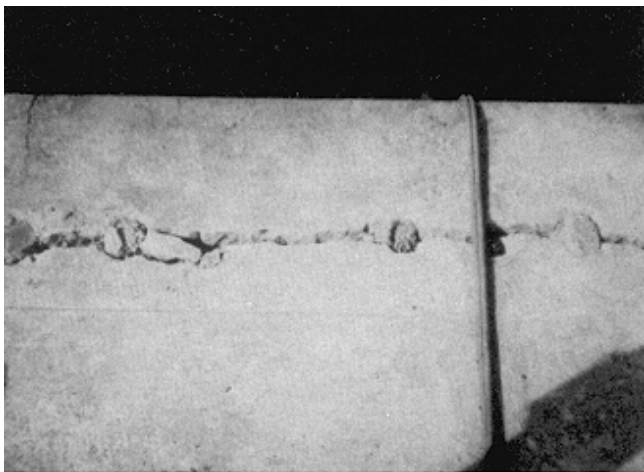

Figure 5-12. Presplitting using chemical-expansive agent

horizontal holes. The newer expansive agents produce presplitting planes in 4 hr or less. Rotary-head milling or mechanical-impacting methods will be required to complete removal.

(2) Mechanical presplitting, piston-jack splitter. Piston-jack splitters (Figure 5-13) are applicable for presplitting more massive concrete structures where 250 mm (10 in.) or more of the face is to be removed and presplitting requires boreholes of a depth greater than can be used by plug-and-feather splitters. The piston-jack splitters initiate presplitting from opposite sides of a borehole, normal to the direction of piston movement. The splitters are reinserted into boreholes to continue removal. Process is repeated for full depth of holes. Splitters are typically used in pairs to control the presplitting plane. The primary disadvantages of this method are the cost of drilling the required 90-mm (3-1/2-in.)-diam boreholes and the limited availability of piston-jack devices in the United States.

(3) Mechanical presplitting, plug-feather splitter. Plug-and-feather splitters (Figure 5-14) are applicable for presplitting slabs, walls, and other concrete members where the presplitting depth is 1.2 m (4 ft) or less. Initiation of direction of presplitting can be controlled by orientation of plug and feathers. The primary limitation of these splitters is that they can not be reinserted into boreholes to continue presplitting after the presplit section has been removed, since the body of the tool is wider than the borehole.

*l. Monitoring removal operations.* The extent of damage to the concrete that remains after a removal

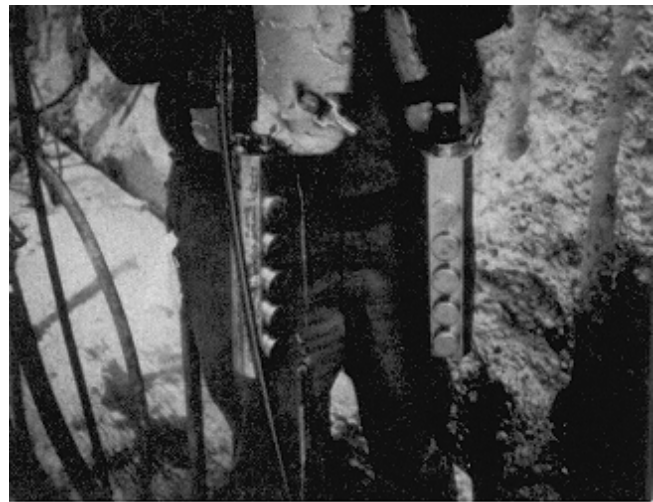

Figure 5-13. Piston-jack splitter

method has been employed is usually evaluated by visual inspection of the remaining surfaces. For a more detailed evaluation, a monitoring program can be implemented. The program may consist of taking cores before and after removal operations, making visual and petrographic examinations, and conducting pulse-velocity and ultimate-strength tests of the cores. A pulse-velocity study of the in situ concrete may also be desired. A comparison of the data obtained before and after removal operations could then be used to determine the relative condition of remaining concrete and to identify damage resulting from the removal method employed. To further document the extent of damage, an instrumentation program may be required.

*m. Quantity of concrete removal.* In most concrete repair projects, all damaged or deteriorated concrete should be removed. However, estimating the quantity of concrete to be removed prior to a repair is not an easy task, especially if it is intended that only unsound concrete be removed. Substantial overruns have been common. Errors in estimating the removal quantity can be minimized by a thorough condition survey as close as possible to the time the repair work is executed. When, by necessity, the condition survey is done far in advance of the repair work, the estimated quantities should be increased to account for continued deterioration.

*n. Vibration and damage control.* Blasting operations in or adjacent to buildings, structures, or other facilities should be carefully planned with full consideration of all forces and conditions involved. Appropriate vibration

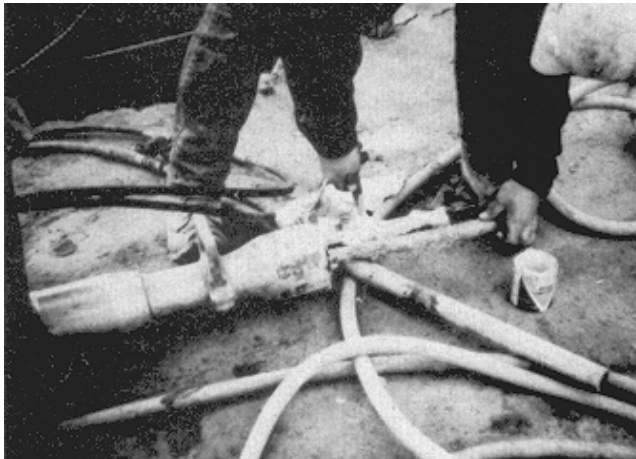

Figure 5-14. Plug-and-feather splitter

and damage control should be established in accordance with EM 385-1-1.

### 5-3. Preparation for Repair

One of the most important steps in the repair or rehabilitation of a concrete structure is the preparation of the surface to be repaired. The repair will only be as good as the surface preparation, regardless of the nature or sophistication (expense) of the repair material. For reinforced concrete, repairs must include proper preparation of the reinforcing steel to develop bond with the replacement concrete to ensure desired behavior in the structure. Preparation of concrete and reinforcing steel after removal of deteriorated concrete and anchor systems are discussed in the following.

#### *a. Concrete surfaces.*

##### (1) General considerations.

(a) The desired condition of the concrete surface immediately before beginning a repair depends somewhat on the type of repair being undertaken. For example, a project involving the application of a penetrating sealer may require only a broom-cleaned dry surface, whereas another project involving the placement of a latex-modified concrete overlay may require a sound, clean, rough-textured, wet surface. However, the desired condition of the prepared surface for most repairs will be sound, clean, rough-textured, and dry.

(b) Concrete is removed to a fixed depth for many maintenance and repair projects, leaving local areas of deteriorated concrete that must be removed as part of the surface preparation work. This secondary removal is typically accomplished with hand-held impact tools. Boom-mounted breakers and rotary-head milling are frequently used to remove nonreinforced concrete where extensive amounts of secondary removal are required.

(c) In most concrete repair projects, all damaged or deteriorated material should be removed. However, it is not always easy to determine when all such material has been removed. The best recommendation is to continue to remove material until aggregate particles are being broken rather than simply being removed from the cement matrix.

(d) Whenever concrete is removed with impact tools or by rotary-head milling, there is the potential for very small-scale damage to the surface of the concrete left in place. Unless this damaged layer is removed, the replacement material will suffer what appears to be a bond failure. Thus, a perfectly sound and acceptable replacement material may fail because of improper surface preparation.

(e) Following secondary removal, all exposed surfaces should be prepared with dry or wet sandblasting or water-jet blasting to remove any damaged surface material. Surfaces that were exposed by water-jet blasting will typically not require this surface preparation.

(2) Methods of surface preparation.

(a) Chemical cleaning. In cases in which concrete is contaminated with oil, grease, or dirt, these contaminants must be removed prior to placement of repair materials. Detergents, trisodium phosphate, and various other proprietary concrete cleaners are available for this work. It is also important that all traces of the cleaning agent be removed after the contaminating material is removed. Solvents should not be used to clean concrete since they dissolve the contaminants and carry them deeper into the concrete. Muriatic acid, commonly used to etch concrete surfaces, is relatively ineffective for removing grease or oil.

(b) Mechanical cleaning. There is a variety of mechanical devices available for cleaning concrete surfaces. These devices include scabblers, scarifiers, and impact tools. Depending upon the hammer heads used or the nature of the abrasive material, a variety of degrees of surface preparation may be achieved. After use of one of these methods, it may be necessary to use another means (waterjetting or wet sandblasting) for final cleaning of the surface.

(c) Shot blasting. Steel shot blasting produces a nearly uniform profile that is ideally suited for thin overlay repairs. It can produce light-brush blasting to 6-mm (1/4-in.)-depth removal depending on the size shot selected and the duration of the removal effort. The debris is vacuumed up and retained by the unit. Steel shot blasting leaves the surface dry for immediate application of a bonding agent, coating, or overlay.

(d) Blast cleaning. Blast cleaning includes wet and dry sandblasting, and water jetting. When sandblasting is used, the air source must be equipped with an effective oil trap to prevent contamination of the concrete surface during the cleaning operation. Water-jetting equipment

with operating pressures of 40 to 70 MPa (6,000 to 10,000 psi) is commercially available for cleaning concrete. This equipment is very effective when used as the final step in surface preparation.

(e) Acid etching. Acid etching of concrete surfaces has long been used to remove laitance and normal amounts of dirt. The acid will remove enough cement paste to provide a roughened surface which will improve the bond of replacement materials. ACI 515.1R recommends that acid etching be used only when no alternative means of surface preparation can be used. The preparation methods described earlier are believed to be more effective than acid treatment. If acid is used, the surface should be cleaned of grease and oil with appropriate agents, and the cleaning agents should be rinsed off the surface before the acid is added. Acid is then added at a rate of approximately 1 L/sq m (1 qt/sq yd), and it should be worked into the concrete surface with a stiff brush or broom. When the foaming stops (3 to 5 min), the acid should be rinsed off, and brooms should be used to remove reaction products and any loosened particles. The surface should be checked with litmus or pH paper to determine that all acid has been removed.

(f) Bonding agents. The general guidance is that small thin patches (less than 50 mm (2 in.) thick) should receive a bonding coat while thicker replacements probably do not require any bonding agent. Excellent bond of fresh-to-hardened concrete can be achieved with proper surface preparation and without the use of bonding agents. The most common bonding agents are simply grout mixtures of cement slurry or equal volumes of portland cement and fine aggregate mixed with water to the consistency of thick cream. The grout must be worked into the surface with stiff brooms or brushes. The grout should not be allowed to dry out before the concrete is placed. A maximum distance of 1.5 m (5 ft) or a period of 10 min ahead of the concrete placement are typical figures used in the specification. There is a wide variety of epoxy and other polymer bonding agents available. If one of these products is used, the manufacturer's recommendations must be followed. Improperly applied bonding agents can actually reduce bond.

*b. Reinforcing steel.*

(1) General considerations.

(a) By far, the most frequent cause of damage to reinforcing steel is corrosion. Other possible causes of damage are fire and chemical attack. The same basic

preparation and repair procedures may be used for all of these causes of damage.

(b) Once the cause and the magnitude of the damage have been determined, it remains to expose the steel, evaluate its structural condition, and prepare the reinforcement for the placement of the repair material. Proper steps to prepare the reinforcement will ensure that the repair method is a permanent solution rather than a temporary solution that will deteriorate in a short period of time.

(2) Removal of concrete surrounding reinforcing steel. The first step in preparing reinforcing steel for repair is the removal of the deteriorated concrete surrounding the steel. Usually, the deteriorated concrete above the top reinforcement can be removed with a jackhammer. For this purpose, a light (14-kg (30-lb)) hammer should be sufficient and should not significantly damage sound concrete at the periphery of the damaged area. Extreme care should be exercised to ensure that further damage to the reinforcing steel is not inflicted in the process of removing the deteriorated concrete. Jackhammers can heavily damage reinforcing steel if the hammer is used without knowledge of the location of the steel. For this reason, a copy of the structural drawings should be used to determine where the reinforcement is located and its size, and a pathometer should be used to determine the depth of the steel in the concrete. Once the larger pieces of the damaged concrete have been removed, a (7-kg (15-lb)) chipping hammer should be used to remove the concrete in the vicinity of the reinforcement. Water-jet blasting may also be used for removal of concrete surrounding the reinforcing steel.

(3) How much concrete to remove. Obviously, all weak, damaged, and easily removable concrete should be chipped away. If more than one-half of the perimeter of the bar has been exposed during removal of deteriorated concrete, then concrete removal should continue to give a clear space behind the reinforcing steel of 6 mm (1/4 in.) plus the dimension of the maximum size aggregate. If less than one-half of the perimeter of a bar is exposed after concrete removal, the bar should be inspected, cleaned as necessary, and then repairs should proceed without further concrete removal. However, if inspection indicates that a bar or bars must be replaced, concrete must be removed to give the clear space indicated above.

(4) Inspection of reinforcing steel. Once deteriorated concrete has been removed, reinforcing steel should be carefully inspected. If the cross-sectional area of a bar has been significantly reduced by corrosion or other

means, the steel may have to be replaced. If there is any question concerning the ability of the steel to perform as designed, a structural engineer should be consulted. Project specifications should include a provision whereby decisions concerning repair versus replacement of reinforcing steel can be made during the project as the steel is exposed.

(5) Replacing reinforcing steel. The easiest method of replacing reinforcement is to cut out the damaged area and splice in replacement bars. A conventional lap splice is preferred. The requirements for length of lap should conform to the requirements of ACI 318. If mechanical splices are considered, their use should be approved by a structural engineer. If a welded splice is used, it should also be performed in accordance with ACI 318. Butt welding should be avoided because of the high degree of skill required to perform a full penetration weld. High-strength steel should not be welded.

(6) Cleaning reinforcing steel.

(a) When it has been determined that the steel does not need replacing, the steel should be thoroughly cleaned of all loose rust and foreign matter before the replacement concrete is placed. For limited areas, wire brushing or other hand methods of cleaning are acceptable. For larger areas, dry sandblasting is the preferred method. The sandblasting must remove all the rust from the underside of the reinforcing bars. Normally, the underside is not directly hit by the high-pressure sand particles and must rely on rebound force as the sand comes off the substrate concrete surface. The operator must be suited with a respiratory device because of the health hazard associated with dry blasting.

(b) The type of air compressor used in conjunction with sandblasting is important. When the steel is cleaned and loose particles are blown out of the patch area after cleaning, it is important that neither the reinforcing steel nor the concrete substrate surface be contaminated with oil from the compressor. For this reason, either an oil-free compressor or one that has a good oil trap must be used.

(c) Alternative methods of cleaning the steel are wet sandblasting or water-jet blasting. These methods are not as good as dry sandblasting, because they provide the water and oxygen necessary to begin the corrosion process again once the steel has been cleaned.

(d) There is always the possibility that freshly cleaned reinforcing steel will rust between the time it is

cleaned and the time that the next concrete is placed. If the rust that forms is tightly bonded to the steel, there is no need to take further action. If the rust is loosely bonded or in any other way may inhibit bonding between the steel and the concrete, the reinforcing bars must be cleaned again immediately before concrete placement.

*c. Anchors.* Dowels may be required in some situations to anchor the repair material to the existing concrete substrate. ACI 355.1R summarizes anchor types and provides an overview of anchor performance and failure modes under various loading conditions. It also covers design and construction considerations and summarizes existing requirements in codes and specifications. Design criteria for anchoring relatively thin sections (less than 0.8 m (2.5 ft)) of cast-in-place concrete are described in Section 8-1. Anchor installation underwater is discussed in Section 8-6. Most of the anchors used in repair are installed in holes drilled in the concrete substrate and can be classified as either bonded or expansion anchors.

(1) Drilling. Anchor holes should be drilled with rotary carbide-tipped or diamond-studded bits or hand-hammered star drill bits. Drilling with a jackhammer is not recommended because of the damage that results immediately around the hole from the impact. Holes should be cleaned with compressed air and plugged with a rag or other suitable material until time for anchor installation. Holes should be inspected for proper location, diameter, depth, and cleanliness prior to installation of anchors.

(2) Bonded anchors. Bonded anchors are headed or headless bolts, threaded rods, or deformed reinforcing bars. Bonded anchors are classified as either grouted anchors or chemical anchors.

(a) Grouted anchors are embedded in predrilled holes with neat portland cement, portland cement and sand, or other commercially available premixed grout. An expansive grout additive and accelerator are commonly used with cementitious grouts.

(b) Chemical anchors are embedded in predrilled holes with two-component polyesters, vinylesters, or epoxies. The chemicals are available in four forms: glass capsules, plastic cartridges, tubes (“sausages”), or bulk. Following insertion into the hole, the glass capsules and tubes are both broken and their contents mixed by insertion and spinning of the anchor. The plastic cartridges are used with a dispenser and a static mixing nozzle to mix the two components as they are placed in the drill hole. Bulk systems are predominately epoxies which are mixed in a pot, or pumped through a mixer and injected into the hole after which the anchor is immediately inserted.

(c) Some chemical grouts creep under sustained loading, and some lose their strength when exposed to temperatures over 50 °C (120 °F). Creep tests were conducted, as part of the REMR Research Program, by subjecting anchors to sustained loads of 60 percent of their yield strength for 6 months. The slippage exhibited by anchors embedded in polyester resin was approximately 30 times higher than that of anchors embedded in portland-cement (Best and McDonald 1990b).

(3) Expansion anchors. Expansion anchors are designed to be inserted into predrilled holes and then expanded by either tightening a nut, hammering the anchor, or expanding into an undercut in the concrete. Expansion anchors that rely on side point contact to create frictional resistance should not be used where anchors are subjected to vibratory loads. Some wedge-type anchors perform poorly when subjected to impact loads. Undercut anchors are suitable for dynamic and impact loads.

(4) Load tests. Following installation, randomly selected anchors should be tested to ensure compliance with the specifications. In some field tests, anchors have exhibited significant slippage prior to achieving the desired tensile capacity. Therefore, it may be desirable to specify a maximum displacement in addition to the minimum load capacity.

## Chapter 6

### Materials and Methods for Repair and Rehabilitation

#### 6-1. Introduction

This chapter contains descriptions of various materials and methods that are available for repair or rehabilitation of concrete structures. Each of the entries in this chapter will include description, applications and limitations, and procedure. Although the repair procedures given in this chapter are current practice, they may not be used directly in project specifications because each repair project may require unique remedial action. Emmons (1993) provides a discussion of materials and methods for concrete repair with extensive, detailed illustrations.

#### 6-2. Additional Reinforcement

*a. Description.* Additional reinforcement, as the name implies, is the provision of additional reinforcing steel, either conventional reinforcement or prestressing steel, to repair a cracked concrete section. In either case, the steel that is added is to carry the tensile forces that have caused cracking in the concrete.

*b. Applications and limitations.* Cracked reinforced concrete bridge girders have been successfully repaired by use of additional conventional reinforcement (Stratton, Alexander, and Nolting 1982). Posttensioning is often the desirable solution when a major portion of a member must be strengthened or when the cracks that have formed must be closed. For the posttensioning method, some form of abutment is needed for anchorage, such as a strongback bolted to the face of the concrete, or the tendons can be passed through and anchored in connecting framing.

*c. Procedure.*

##### (1) Conventional reinforcement.

(a) This technique consists of sealing the crack, drilling holes 19 mm (3/4 in.) in diam at 90 deg to the crack plane (Figure 6-1), cleaning the hole of dust, filling the hole and crack plane with an adhesive (typically epoxy) pumped under low pressure 344 to 552 KPa (50 to 80 psi), and placing a reinforcing bar into the drilled hole. Typically, No. 4 or 5 bars are used, extending at least 0.5 m (1.6 ft) on each side of the crack. The adhesive

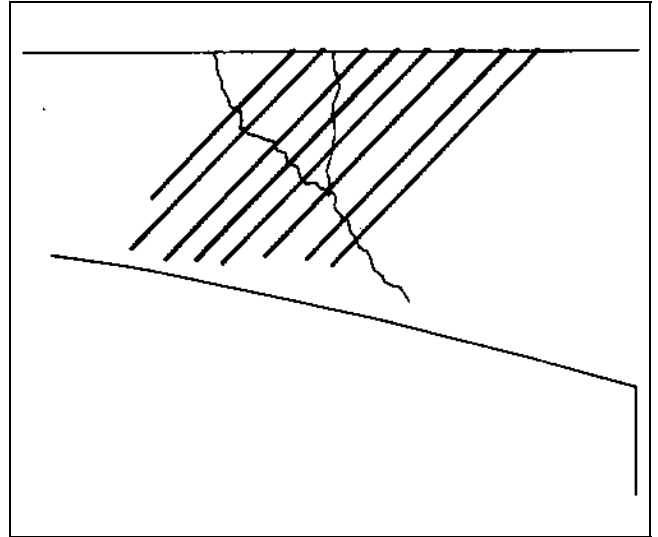

**Figure 6-1. Crack repair using conventional reinforcement with drillholes 90 deg to the crack plane**

bonds the bar to the walls of the hole, fills the crack plane, bonds the cracked concrete surfaces together in one monolithic form, and thus reinforces the section.

(b) A temporary elastic crack sealant is required for a successful repair. Gel-type epoxy crack sealants work very well within their elastic limits. Silicone or elastomeric sealants work well and are especially attractive in cold weather or when time is limited. The sealant should be applied in a uniform layer approximately 1.6 to 2.4 mm (1/16 to 3/32 in.) thick and should span the crack by at least 19 mm (3/4 in.) on each side.

(c) Epoxy adhesives used to rebond the crack should conform to ASTM C 881, Type I, low-viscosity grade.

(d) The reinforcing bars can be spaced to suit the needs of the repair. They can be placed in any desired pattern, depending on the design criteria and the location of the in-place reinforcement.

(e) Concrete elements may also be reinforced externally by placement of longitudinal reinforcing bars and stirrups or ties around the members and then encasing the reinforcement with shotcrete or cast-in-place concrete. Also, girders and slabs have been reinforced by addition of external tendons, rods, or bolts which are prestressed. The exterior posttensioning is performed with the same equipment and design criteria of any posttensioning project. If desirable for durability or for esthetics, the exposed posttensioning strands may be covered by concrete.

(2) Prestressing steel. This technique uses prestressing strands or bars to apply a compressive force (Figure 6-2). Adequate anchorage must be provided for the prestressing steel, and care is needed so that the problem will not merely migrate to another part of the structure. The effects of the tensioning force (including eccentricity) on the stress within the structure should be carefully analyzed. For indeterminate structures posttensioned according to this procedure, the effects of secondary moments and induced reactions should be considered.

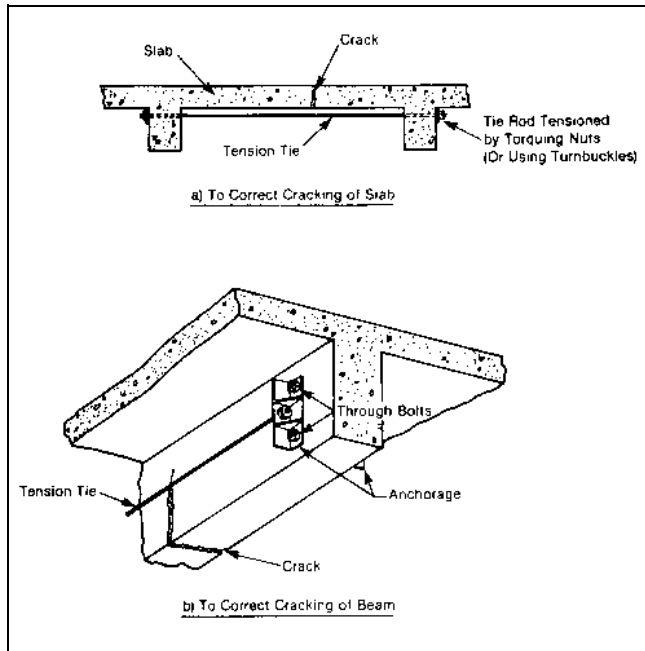

**Figure 6-2. Crack repair with use of external prestressing strands or bars to apply a compressive force**

(3) Steel plates. Cracks in slabs on grade have been repaired by making saw cuts 50 to 75 mm (2 to 3 in.) deep across the crack and extending 150 to 300 mm (6 to 12 in.) on either side of the crack, filling the saw cuts and the crack with epoxy, and forcing a steel plate of appropriate size into each saw cut.

### 6-3. Autogenous Healing

*a. Description.* Autogenous healing is a natural process of crack repair that can occur in the presence of moisture and the absence of tensile stress (Lauer 1956).

*b. Applications and limitations.* Autogenous healing has practical application for closing dormant cracks in a moist environment. Healing will not occur if the crack is active and is subjected to movement during the healing

period. Healing will also not occur if there is a positive flow of water through the crack which dissolves and washes away the lime deposit. A partial exception is a situation in which the flow of water is so slow that complete evaporation occurs at the exposed face causing redeposition of the dissolved salts.

*c. Mechanism.* Healing occurs through the carbonation of calcium hydroxide in the cement paste by carbon dioxide, which is present in the surrounding air and water. Calcium carbonate and calcium hydroxide crystals precipitate, accumulate, and grow within the cracks. The crystals interlace and twine, producing a mechanical bonding effect, which is supplemented by chemical bonding between adjacent crystals and between the crystals and the surfaces of the paste and the aggregate. As a result, some of the tensile strength of the concrete is restored across the cracked section, and the crack may become sealed. Saturation of the crack and the adjacent concrete with water during the healing process is essential for developing any substantial strength. Continuous saturation accelerates the healing. A single cycle of drying and reimmersion will produce a drastic reduction in the amount of healing.

### 6-4. Conventional Concrete Placement

*a. Description.* This method consists of replacing defective concrete with a new conventional concrete mixture of suitable proportions that will become an integral part of the base concrete. The concrete mixture proportions must provide for good workability, strength, and durability. The repair concrete should have a low w/c and a high percentage of coarse aggregate to minimize shrinkage cracking.

*b. Applications and limitations.* If the defects in the structure go entirely through a wall or if the defects go beyond the reinforcement and if the defective area is large, then concrete replacement is the desired method. Replacement is sometimes necessary to repair large areas of honeycomb in new construction. Conventional concrete should not be used for replacement in areas where an aggressive factor which has caused the deterioration of the concrete being replaced still exists. For example, if the deterioration noted has been caused by acid attack, aggressive-water attack, or even abrasion-erosion, it is doubtful that repair by conventional-concrete placement will be successful unless the cause of deterioration is removed. Concrete replacement methods for repairing lock walls and stilling basins are given in Sections 8-1 and 8-3, respectively, and repair by placing a thin concrete overlay is discussed in Section 6-17.



c. Procedure.

(1) Concrete removal is always required for this type of repair. Removal of affected areas should continue until there is no question that sound concrete has been reached. Additional chipping may be necessary to attain a satisfactory depth (normally 150 mm (6 in.) or more) and to shape the cavity properly. Final chipping should be done with a light hammer to remove any unsound concrete that remains. In a vertical surface (Figure 6-3), the cavity should have the following:

- (a) A minimum of spalling or featheredging at the periphery of the repair area.
- (b) Vertical sides and horizontal top at the surface of the member (the top line of the cavity may be stepped).
- (c) Inside faces generally normal to the formed surface, except that the top should slope up toward the front at about a 1:3 slope.
- (d) Keying as necessary to lock the repair into the structure.
- (e) Sufficient depth to reach at least 6 mm (1/4 in.) plus the dimension of the maximum size aggregate behind any reinforcement.

(f) All interior corners rounded with a radius of about 25 mm (1 in.).

(2) Surfaces must be thoroughly cleaned by sandblasting (wet or dry), shotblasting, or another equally satisfactory method, followed by final cleaning with compressed air or water. Sandblasting effects should be confined to the surface that is to receive the new concrete. Dowels and reinforcement are often installed to make the patch self-sustaining and to anchor it to the underlying concrete, thus providing an additional safety factor.

(3) Forming will usually be required for massive repairs in vertical surfaces. The front form and the back form, where one is required, should be substantially constructed and mortar-tight. The back form may be assembled in one piece, but the front panel should be constructed as placing progresses so that the concrete can be conveniently placed in lifts. The contact surface should be dry at the time of patching. Small, thin repairs (less than 50 mm (2 in.) thick) should receive a bonding coat while thicker placements usually do not require a bonding coat (see paragraph 5-3a(2)(f)). The surface is first carefully coated with a thin layer of mortar, not exceeding 3 mm (1/8 in.) in thickness, containing sand passing the No. 16 sieve, and having the same w/c as the concrete to be used in the replacement. Hand-rubbing the mortar into the surface is effective. Epoxy resin

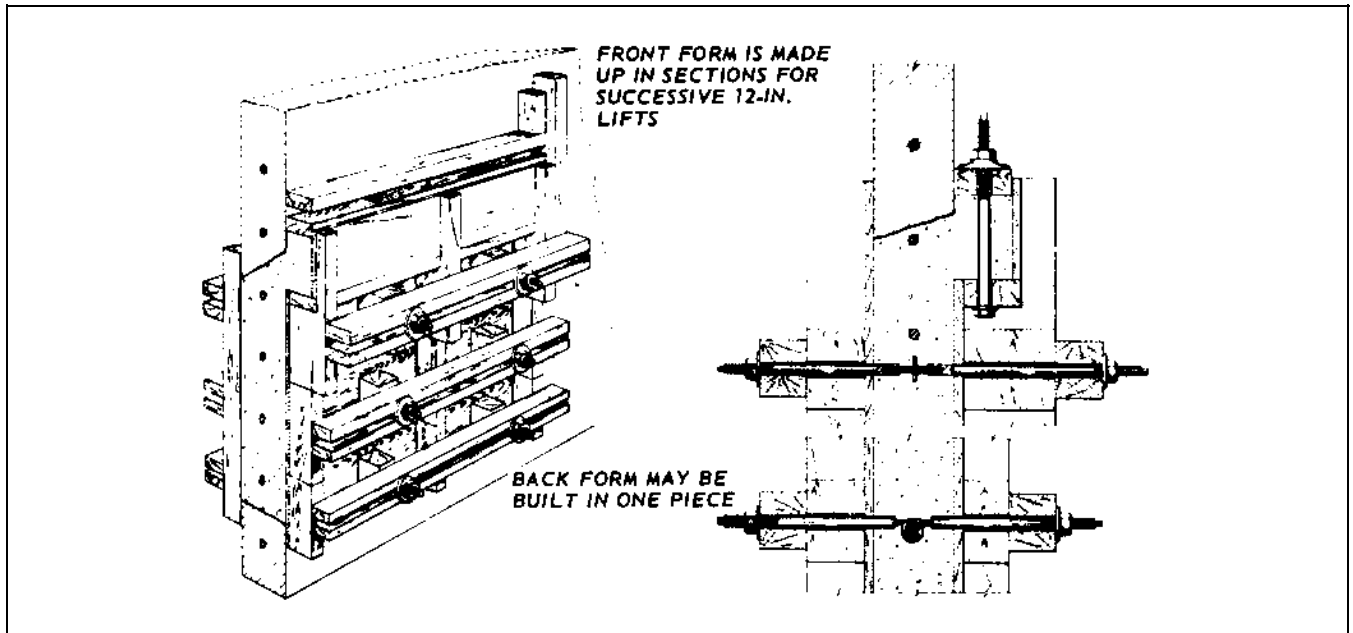

Figure 6-3. Detail of form for concrete replacement in walls after removal of all unsound concrete

meeting ASTM C 881, Type II or Type V may also be used. ACI 503.2 provides a standard specification for bonding plastic concrete to hardened concrete with epoxy adhesives.

(4) Concrete used for repair should conform to EM 1110-2-2000. To minimize strains caused by temperature, moisture change, shrinkage, etc., concrete for the repair should generally be similar to the old concrete in maximum size of aggregate and w/c. Each lift should be thoroughly vibrated. Internal vibration should be used except where accessibility and size of placement will not allow it. If internal vibration can not be used, external vibration may be used. If external vibration must be used, placement through a chimney, followed by a pressure cap (Figure 6-3) should be required. If good internal vibration can be accomplished, the pressure cap may not be needed. The slump should be as low as practical, and a chimney and pressure cap should be used. A tighter patch results if the concrete is placed through a chimney at the top of the front form.

(5) When external vibration is necessary, immediately after the cavity has been filled, a pressure cap should be placed inside the chimney (Figure 6-3). Pressure should be applied while the form is vibrated. This operation should be repeated at 30-min intervals until the concrete hardens and no longer responds to vibration. The projection left by the chimney should normally be removed the second day. Proper curing is essential.

(6) The form and pump technique is often used to place conventional concrete (or other materials) in vertical or over head applications. The proper size variable output concrete pump is used to pump concrete into a cavity confined by formwork. Care must be taken to trim the original concrete surfaces that may entrap air, or these areas may be vented. Forming must be nearly watertight and well braced so that pressure from the pumps can help achieve bonding of the new concrete to the old.

(7) Curing of concrete repairs is very important, especially if relatively thin repairs are made in hot weather. Shrinkage cracks can develop quickly under such conditions. Moist curing conforming to the guidelines in EM 1110-2-2000 is the preferred curing method.

## 6-5. Crack Arrest Techniques

*a. Description.* Crack arrest techniques are those procedures that may be used during the construction of a massive concrete structure to stop crack propagation into subsequent concrete lifts.

*b. Applications and limitations.* These techniques should be used only for cracking caused by restrained volume change of the concrete. They should not be used for cracking caused by excessive loading.

*c. Procedure.* During construction of massive concrete structures, contraction cracks may develop as the concreting progresses. Such cracks may be arrested by use of the following techniques.

(1) The simplest technique is to place a grid of reinforcing steel over the cracked area. The reinforcing steel should be surrounded by conventional concrete rather than the mass concrete being used in the structure.

(2) A somewhat more complex procedure is to use a piece of semicircular pipe as shown in Figure 6-4. The installation procedure is as follows: First, the semicircular pipe is made by splitting a 200-mm (8-in.)-diam piece of 16-gauge pipe and bending it to a semicircular shape with about a 76-mm- (3-in.-) flange on each side. Then, the area surrounding the crack should be well cleaned and the pipe should be centered on the crack. Once in place, the sections of the pipe should be welded together. Holes should be cut into the pipe to receive grout pipes. Finally, the pipe section should be covered with concrete placed concentrically by hand methods. The grout pipes may be used for grouting at a later date to attempt to restore structural integrity of the cracked section.

(3) A piece of bond-breaking membrane placed on a construction joint over the crack has been used with varying degrees of success.

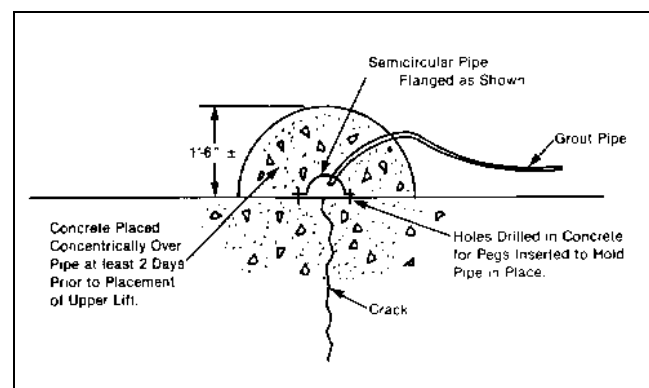

**Figure 6-4. The use of a semicircular pipe in the crack arrest method of concrete repair**

## 6-6. Drilling and Plugging

a. *Description.* Drilling and plugging a crack consists of drilling down the length of the crack and grouting it to form a key (Figure 6-5).

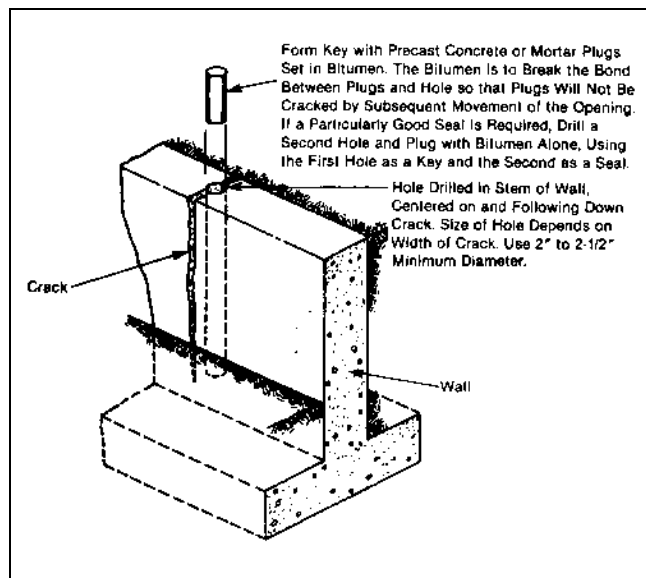

Figure 6-5. Repair of crack by drilling and plugging

b. *Applications and limitations.* This technique is applicable only where cracks run in reasonably straight lines and are accessible at one end. This method is most often used to repair vertical cracks in walls.

(1) *Procedure.* A hole (typically 50 to 75 mm (2 to 3 in.) in diam) should be drilled, centered on, and following the crack. The hole must be large enough to intersect the crack along its full length and provide enough repair material to structurally take the loads exerted on the key. The drilled hole should then be cleaned and filled with grout. The grout key prevents transverse movement of the sections of concrete adjacent to the crack. The key will also reduce heavy leakage through the crack and loss of soil from behind a leaking wall.

(2) If watertightness is essential and structural load transfer is not, the drilled hole should be filled with a resilient material of low modulus such as asphalt or polyurethane foam in lieu of portland-cement grout. If the keying effect is essential, the resilient material can be placed in a second hole, the first being grouted.

## 6-7. Drypacking

a. *Description.* Drypacking is a process of ramming or tamping into a confined area a low water-content mortar. Because of the low w/c material, there is little shrinkage, and the patch remains tight and is of good quality with respect to durability, strength, and watertightness. This technique has an advantage in that no special equipment is required. However, the method does require that the craftsman making the repair be skilled in this particular type of work.

b. *Applications and limitations.* Drypacking can be used for patching rock pockets, form tie holes, and small holes with a relatively high ratio of depth to area. It should not be used for patching shallow depressions where lateral restraint cannot be obtained, for patching areas requiring filling in back of exposed reinforcement, nor for patching holes extending entirely through concrete sections. Drypacking can also be used for filling narrow slots cut for the repair of dormant cracks. The use of drypack is not recommended for filling or repairing active cracks.

c. *Procedure.*

(1) The area to be repaired should be undercut slightly so that the base width is slightly greater than the surface width. For repairing dormant cracks, the portion adjacent to the surface should be widened to a slot about 25 mm (1 in.) wide and 25 mm (1 in.) deep. This is most conveniently done with a power-driven sawtooth bit. The slot should also be undercut slightly. After the area or slot is thoroughly cleaned and dried, a bond coat should be applied. Placing of the drypack mortar should begin immediately. The mortar usually consists of one part cement, two and one-half to three parts sand passing a No. 16 sieve, and only enough water so that the mortar will stick together when molded into a ball by slight pressure of the hands and will not exude water but will leave the hands dry. Latex-modified mortar is being increasingly used in lieu of straight portland-cement mortar. Preshrunk mortar may be used to repair areas too small for the tamping procedure. Preshrunk mortar is a low water-content mortar that has been mixed and allowed to stand idle 30 to 90 min, depending on the temperature, prior to use. Remixing is required after the idle period.

(2) Drypack mortar should be placed in layers having a compacted thickness of about 10 mm (3/8 in.).

Each layer should be compacted over its entire surface by use of a hardwood stick. For small areas, the end of the stick is placed against the mortar and tamping is begun at the middle of the area and progresses toward the edges to produce a wedging effect. For larger areas, a T-shaped rammer may be used; the flat head of the T is placed against the mortar and hammered on the stem. It is usually necessary to scratch the surface of the compacted layers to provide bond for the next layer. Successive layers of drypack are placed without interval, unless the material becomes spongy, in which case there should be a short wait until the surface stiffens. Areas should be filled flush and finished by striking a flat-sided board or the flat of the hardwood stick against the surface. Steel trowelling is not suitable. After being finished, the repaired area should be cured. If the patch must match the color of the surrounding concrete, a blend of portland cement and white cement may be used. Normally, about one-third white cement is adequate, but the precise proportions can only be determined by trial.

### 6-8. Fiber-Reinforced Concrete

*a. Description.* Fiber-reinforced concrete is composed of conventional portland-cement concrete containing discontinuous discrete fibers. The fibers are added to the concrete in the mixer. Fibers are made from steel, plastic, glass, and other natural materials. A convenient numerical parameter describing a fiber is its aspect ratio, defined as the fiber length divided by an equivalent fiber diameter. Typical aspect ratios range from about 30 to 150 for lengths of 6.4 to 76 mm (0.25 to 3 in.).

*b. Applications and limitations.* Fiber-reinforced concrete has been used extensively for pavement repair. Fiber-reinforced concrete has been used to repair erosion of hydraulic structures caused by cavitation or high velocity flow and impact of large debris (ACI 210R). However, laboratory tests and field experience show that the abrasion-erosion resistance of fiber-reinforced concrete is significantly less than that of conventional concrete with the same w/c and aggregate type (Liu 1980, Liu and McDonald 1981). The slump of a concrete mixture is significantly reduced by the addition of fibers. Use of the inverted slump cone test for workability is recommended. Reliance on slump tests often results in the use of excessive water in an attempt to maintain a slump, without improving workability. A fiber mixture will generally require more vibration to consolidate the concrete.

*c. Procedure.* Preparation of the area to be repaired, mixing, transporting, placing, and finishing fiber-reinforced concrete follows the procedures for and

generally uses the same equipment as plain concrete (ACI 544.3R). Pumping of steel fiber-reinforced concrete with up to 1.5 percent fibers by volume has been done successfully. Three-pronged garden forks are preferable to shovels for handling the fiber-reinforced concrete. Mixture design and especially the amount of fibers used are critical so that design parameters for strength and durability are met and the mixture will still be workable. About 2 percent by volume is considered a practical upper limit for field placement with the necessary workability. Steel fiber-reinforced shotcrete, with up to 2.0 percent fibers by volume, generally mixed with the dry-mixture process has been successfully used to repair concrete. Polypropylene fibers have been added to acrylic polymer modified concrete for repair of a lockwall (Dahlquist 1987).

### 6-9. Flexible Sealing

*a. Description.* Flexible sealing involves routing and cleaning the crack and filling it with a suitable field-molded flexible sealant. This technique differs from routing and sealing in that, in this case, an actual joint is constructed, rather than a crack simply being filled.

*b. Applications and limitations.* Flexible sealing may be used to repair major, active cracks. It has been successfully used in situations in which there is a limited water head on the crack. This repair technique does not increase the structural capacity of the cracked section. Another process used to form a flexible joint from an active or inactive water-filled crack is described in Section 6-11. This process may be used in lieu of or in addition to flexible sealing. Chemical grouting is a more complicated and expensive procedure, but it can be used in conditions of flowing water.

*c. Procedure.* Active cracks can be routed out; cleaned by sandblast or air-water jet, or both; and filled with a suitable field-molded flexible sealant (ACI 224.1R). As nearly as is practical, the sealant reservoir (slot) formed by routing should comply with the requirements for width and shape factor of a joint having equivalent movement. The selection of a suitable sealant and installation method should follow that for equivalent joints (ACI 504R).

(1) A bond breaker should be provided at the bottom of the slot to allow the sealant to change shape without a concentration of stress on the bottom (Figure 6-6). The bond breaker may be a polyethylene strip, pressure sensitive tape, or other material which will not bond to the sealant before or during cure.

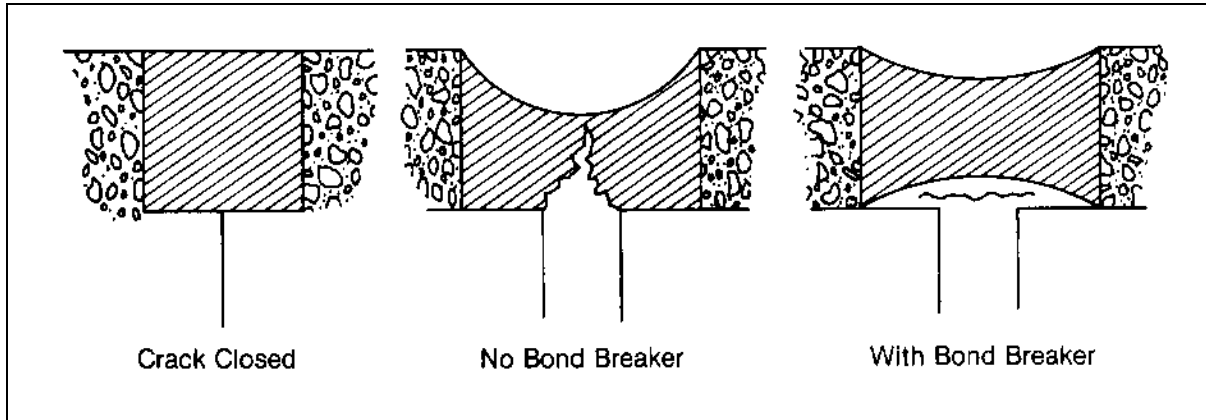

Figure 6-6. Effect of bond breaker involving a field-molded flexible sealant

(2) If a bond breaker is used over the crack, a flexible joint sealant may be trowelled over the bond breaker to provide an adequate bonding area. This is a very economical procedure and may be used on the interior of a tank, on roofs, or other areas not subject to traffic or mechanical abuse.

(3) Narrow cracks subject to movement, where esthetics are not important, may be sealed with a flexible surface seal (Figure 6-7).

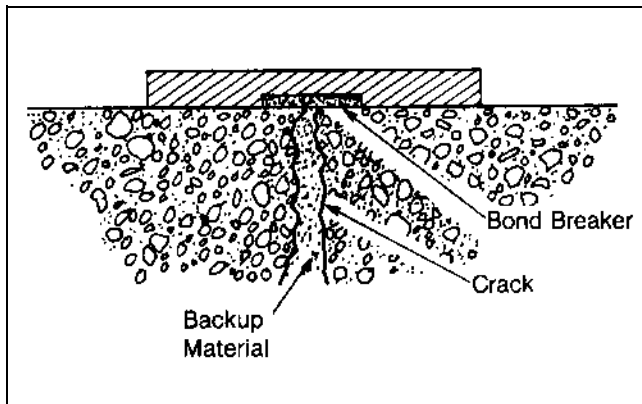

Figure 6-7. Repair of a narrow crack with flexible surface seal

(4) When repairing cracks in canal and reservoir linings or low-head hydraulic structures where water movement or pressure exists, a retaining cap must be used to confine the sealant. A simple retainer can be made by positioning a metal strip across the crack and fastening it to expandable anchors or grouted bolts installed in the concrete along one side of the crack. To maintain hydraulic efficiency in some structures, it may be

necessary to cut the concrete surface adjacent to the crack and to place the retaining cap flush with the original flow lines (Figure 6-8).

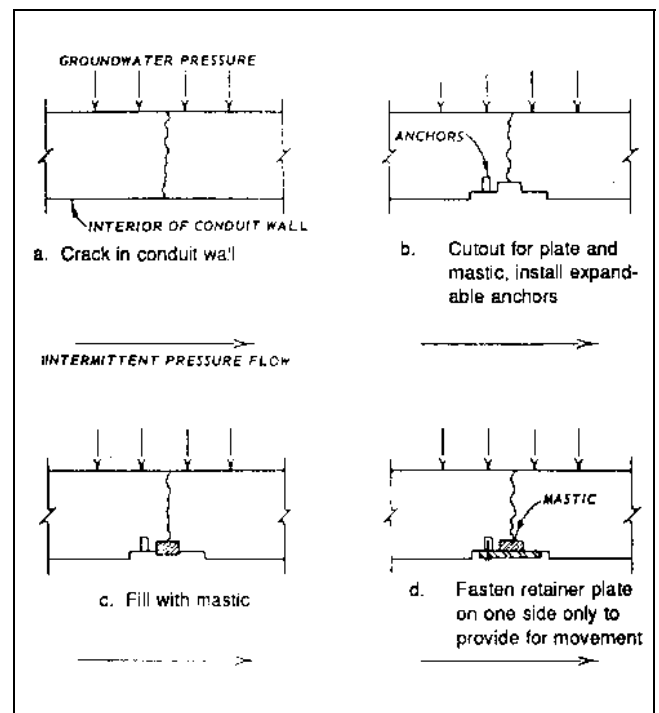

Figure 6-8. Repair of crack by use of a retainer plate to hold mastic in place against external pressure

### 6-10. Gravity Soak

*a. Description.* High molecular weight methacrylate (HMWM) is poured or sprayed onto any horizontal concrete surface and spread by broom or squeegee. The

material penetrates very small cracks by gravity and capillary action, polymerizing to form a “plug” which closes off access to the reinforcing steel (Montani 1993).

*b. Applications and limitations.* Repairing cracks with the gravity soak method and HMWM has become a proven and cost-effective method. Gravity soak can be an effective repair method for horizontal concrete surfaces that contain excessive, closely spaced shrinkage cracking. This would include bridge decks, parking decks, industrial floors, pavements etc. HMWM’s should not be confused with methyl methacrylates (MMA’s). While MMA’s are very volatile and have a low flash point, HMWM’s have a high flashpoint, and are quite safe to use.

*c. Procedure.* New concrete must have cured for at least 1 week and must be air-dry. Air-drying is necessary after a rainfall. New concrete surfaces may simply be swept clean before application, but older surfaces will require cleaning of all oil, grease, tar, or other contaminants and sand blasting. The monomer is mixed with the catalyst and quickly poured onto the concrete surface. Two-component systems should be specified. Three-component systems are not recommended because improper mixing sequences can be dangerous. The material is spread by a broom or squeegee. Larger individual cracks can sometimes be treated by use of a squeegee bottle, in addition to the flooding. It is important that the material not be allowed to puddle so that smooth slick surfaces are formed. Tined or grooved surfaces may require use of a large napped roller to remove excess HVWM. After about 30 min of penetration time, areas of greater permeability or extensive cracking may require additional treatment. A light broadcast of sand is usually recommended after the HMWM initial penetration. Some sand will not adhere and should be removed, but the skid resistance will have been accomplished. The surface will be ready to accept traffic in 3 to 24 hr, according to the formulation used.

### 6-11. Grouting (Chemical)

*a. Description.* Chemical grouts consist of solutions of two or more chemicals that react to form a gel or solid precipitate as opposed to cement grouts that consist of suspensions of solid particles in a fluid (EM 1110-1-3500). The reaction in the solution may be either chemical or physicochemical and may involve only the constituents of the solution or may include the interaction of the constituents of the solution with other substances encountered in the use of the grout. The reaction causes a decrease in fluidity and a tendency to

solidify and fill voids in the material into which the grout has been injected.

*b. Applications and limitations.* Cracks in concrete as narrow as 0.05 mm (0.002 in.) have been filled with chemical grout. The advantages of chemical grouts include their applicability in moist environments, wide limits of control of gel time, and their application in very fine fractures. Disadvantages are the high degree of skill needed for satisfactory use, their lack of strength, and, for some grouts, the requirement that the grout not dry out in service. Also some grouts are highly inflammable and cannot be used in enclosed spaces.

*c. Procedure.* Guidance and information regarding the use of chemical grouts can be found in EM 1110-1-3500.

### 6-12. Grouting (Hydraulic-Cement)

*a. Description.* Hydraulic-cement grouting is simply the use of a grout that depends upon the hydration of portland cement, portland cement plus slag, or pozzolans such as fly ash for strength gain. These grouts may be sanded or unsanded (neat) as required by the particular application. Various chemical admixtures are typically included in the grout. Latex additives are sometimes used to improve bond.

*b. Applications and limitations.* Hydraulic-cement grouts may be used to seal dormant cracks, to bond subsequent lifts of concrete that are being used as a repair material, or to fill voids around and under concrete structures. Hydraulic-cement grouts are generally less expensive than chemical grouts and are better suited for large volume applications. Hydraulic cement grout has a tendency to separate under pressure and thus prevent 100 percent filling of the crack. Normally the crack width at the point of introduction should be at least 3 mm (1/8 in.). Also, if the crack cannot be sealed or otherwise confined on all sides, the repair may be only partially effective. Hydraulic-cement grouts are also used extensively for foundation sealing and treatments during new construction, but such applications are beyond the scope of this manual. See EM 1110-2-3506 for information relative to the use in these areas.

*c. Procedure.* The procedure consists of cleaning the concrete along the crack, installing built-up seats (grout nipples) at intervals astride the crack to provide a pressure-tight contact with the injection apparatus, sealing the crack between the seats, flushing the crack to clean it

and test the seal, and then grouting the entire area. Grout mixtures may vary in volumetric proportion from one part cement and five parts water to one part cement and one part water, depending on the width of the crack. The water-cement ratio should be kept as low as practical to maximize strength and minimize shrinkage. For small volumes, a manual injection gun may be used; for larger volumes, a pump should be used. After the crack is filled, the pressure should be maintained for several minutes to ensure good penetration.

### 6-13. High-Strength Concrete

*a. Description.* High-strength concrete is defined as concrete with a 28-day design compressive strength over 41 MPa (6,000 psi) (ACI 116R). This method is similar to an extension of the conventional concrete placement method described in Section 6-4. Chemical admixtures such as water-reducing admixtures (WRA's) and HRWRA's are usually required to achieve lower w/c and subsequently higher compressive strengths. Mineral admixtures are also frequently used. The special procedures and materials involved with producing high-strength concrete with silica fume are discussed in paragraph 6-30. Guidance on proportioning high-strength concrete mixtures is given in EM 1110-2-2000 and ACI 363R.

*b. Applications and limitations.* High-strength concrete for concrete repair is used to provide a concrete with improved resistance to chemical attack, better abrasion resistance, improved resistance to freezing and thawing, and reduced permeability. The material is slightly more expensive and requires greater control than conventional concrete. A special laboratory mixture design should always be required for high-strength concrete instead of a producers' standard mixture that requires field adjustments.

*c. Procedure.* Generally, concrete production and repair procedures are done in the same way as a conventional concrete. Selection of materials to be used should be based on the intended use of the material and the performance requirements. Curing is more critical with high-strength concrete than with normal-strength concrete. Water curing should be used, if practicable.

### 6-14. Jacketing

*a. Description.* Jacketing consists of restoring or increasing the section of an existing member (principally a compression member) by encasing it in new concrete

(Johnson 1965). The original member need not be concrete; steel and timber sections can be jacketed.

*b. Applications and limitations.* The most frequent use of jacketing is in the repair of piling that has been damaged by impact or is disintegrating because of environmental conditions. It is especially useful where all or a portion of the section to be repaired is underwater. When properly applied, jacketing will strengthen the repaired member as well as provide some degree of protection against further deterioration. However, if a concrete pile is deteriorating because of exposure to acidic water, for example, jacketing with conventional portland-cement concrete will not ensure against future disintegration.

*c. Procedure.* The removal of the existing damaged concrete or other material is usually necessary to ensure that the repair material bonds well to the original material that is left in place. If a significant amount of removal is necessary, temporary support may have to be provided to the structure during the jacketing process. Any suitable form material may be used. A variety of proprietary form systems are available specifically for jacketing. These systems employ fabric, steel, or fiberglass forms. Use of a preformed fiberglass jacket for repair of a concrete pile is shown in Figure 6-9. A steel reinforcement cage may be constructed around the damaged section. Once the form is in place, it may be filled with any suitable material. Choice of the filling material should be based upon the environment in which it will serve as well as a knowledge of what caused the original material to fail. Filling may be accomplished by pumping, by tremie placement, by preplaced aggregate techniques, or by conventional concrete placement if the site can be dewatered.

### 6-15. Judicious Neglect

*a. Description.* As the name implies, judicious neglect is the repair method of taking no action. This method does not suggest ignoring situations in which damage to concrete is detected. Instead, after a careful (i.e., "judicious") review of the circumstances the most appropriate action may be to take no action at all.

*b. Applications and limitations.* Judicious neglect would be suitable for those cases of deterioration in which the damage to the concrete is causing no current operational problems for the structure and which will not contribute to future deterioration of the concrete. Dormant cracks, such as those caused by shrinkage or some other

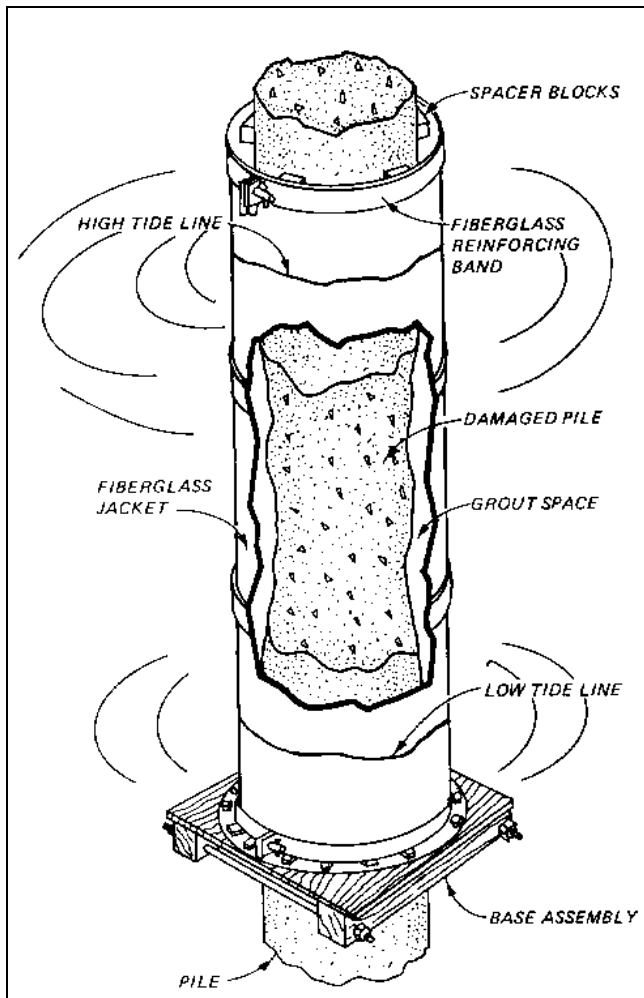

**Figure 6-9. Typical preformed fiberglass jacket being used in repair of a concrete pile**

one-time occurrence, may be self-sealing. This does not imply an autogenous healing and gain of strength, but merely that the cracks clog with dirt, grease, or oil, or perhaps a little recrystallization occurs. The result is that the cracks are plugged, and problems which may have been encountered with leakage, particularly if leakage is the result of some intermittent cause rather than a continuing pressure head, will disappear without doing any repair.

## 6-16. Overlays (Polymer)

*a. Description.* Polymer overlays generally consist of latex-modified concrete, epoxy-modified concrete and epoxy mortar and concrete. Epoxy mortar and concrete contain aggregate and an epoxy resin binder. Latex modified concrete and epoxy modified concrete are

normal portland-cement concrete mixtures to which a water-soluble or emulsified polymer has been added. They are known as polymer portland-cement concretes (PPCC). These materials may be formulated to provide improved bonding characteristics, higher strengths, and lower water and chloride permeabilities compared to conventional concrete (ACI 548.1R).

### *b. Applications and limitations.*

(1) Typically, epoxy mortar or concrete is used for overlay thicknesses of about 6 to 25 mm (0.25 to 1 in.). For overlays between 25 and 51 mm (1 and 2 in.) thick, latex-modified concrete is typically used. Conventional portland-cement concrete is typically used in overlays thicker than about 51 mm (2 in.).

(2) Overlays composed of epoxy mortars or concretes are best suited for use in areas where concrete is being attacked by an aggressive substance such as acidic water or some other chemical in the water. These overlays may also be used in some instances to repair surface cracking, provided that the cause of the cracking is well understood and no movement of the concrete is expected in the future. Possible applications for epoxy-based overlays and coatings must be reviewed very carefully to ensure that the proposed use is compatible with the base material. Thermal compatibility is particularly important in exposed repairs that are subjected to wide variations in temperature.

(3) Slab-on-grade or concrete walls with backfill in freezing climates should never receive an overlay or coating that is a vapor barrier. An impervious barrier will cause moisture passing from the subgrade or backfill to accumulate under or behind the barrier, leading to rapid deterioration by cycles of freezing and thawing. A barrier of this type can be a particular problem where the substrate is nonair-entrained concrete subject to cycles of freezing and thawing.

(4) Latex-modified concrete overlays have been used extensively over the past several years for resurfacing bridge decks and other flat surfaces (Ramakrishnan 1992). More recently an epoxy-modified concrete has come into use with the development of an emulsified epoxy. These overlays may be used in lieu of conventional portland-cement concrete overlays and can be placed as thin as 13 mm (1/2 in.). They have excellent bonding characteristics. They require more care and experience than conventional portland-cement overlays. Also, a special two-phase curing requires more time and labor and is described below.



c. *Procedure.*

(1) Epoxy overlays. Repair of deteriorated concrete with epoxy overlays will involve the use of epoxy concrete or epoxy mortar. Epoxy resin systems conforming to ASTM C 881 (CRD C 595) are suitable.

(a) Generally, aggregates suitable for portland-cement mixtures are suitable for epoxy-resin mixtures. Aggregates are added to the system for economy and improved performance in patching applications and floor toppings. Aggregates should be clean and dry at the time of use and conditioned to a temperature within the range at which the epoxy-resin mortar or concrete is to be mixed. The grading should be uniform with the smallest size passing the No. 100 sieve and the maximum size not to exceed one-third of the mean depth of the patch or opening to be filled. However, the recommended maximum aggregate size for epoxy-resin concrete is 25 mm (1 in.), whereas the maximum size aggregate commonly used for epoxy-resin mortar corresponds to material that will pass a No. 8 sieve.

(b) Aggregates should be used in the amount necessary to ensure complete wetting of the aggregate surfaces. The aggregate-resin proportions will therefore vary with the type and grading of the aggregates. Up to seven parts by weight of the fine aggregate can be mixed with one part of epoxy resin, but a three-to-one proportion is the usual proportion to use for most fine aggregates in making epoxy mortar. For epoxy concrete, the proportion of aggregate to the mixed resin may be as high as 12 to 1 by weight for aggregates in the specific gravity range of 2.50 to 2.80. The aggregate-epoxy proportions also depend on the viscosity of the mixed epoxy system. Since temperature affects the viscosity of the system, the proportions also are dependent on the temperature at which the system is mixed. The trial batches should be made at the temperature of mixing to establish the optimum proportions for the aggregates.

(c) Machine mixing of the epoxy-resin components is mandatory except for mixing volumes of 0.5 L (1 pint) or less. Epoxy mortar or concrete may be machine- or hand-mixed after the epoxy components have been mixed. Small drum mechanical mixers have been used successfully but are difficult to clean properly. Large commercial dough or masonry mortar mixers have been widely and successfully used and present less difficulty in cleaning. Hand-mixing may be performed in metal pans with appropriate tools. When epoxy mortar is hand-mixed, the mixed epoxy system is transferred to the pan, and the fine aggregate is gradually added during mixing. Regardless

of how the epoxy concrete is mixed, the fine aggregate is added first and then the coarse aggregate. This procedure permits proper wetting of the fine aggregate particles by the mixed epoxy system and produces a slightly “wet” mixture to which the coarse aggregate is added.

(d) Prior to placement, a single prime coat of epoxy should be worked into the cleaned substrate by brushing, trowelling, or any other method that will thoroughly wet the substrate. The epoxy mortar or concrete must be applied while the prime coat is in a tacky condition. If the depth of the patch is greater than 500 mm (2 in.), placement should be accomplished in lifts or layers of less than 50 mm (2 in.) with some delay between lifts to permit as much heat dissipation as possible. The delay should not extend beyond the setting time of the epoxy formulation. Hand tampers should be used to consolidate the epoxy concrete, taking great care to trowel the mortar or concrete onto the sides and into the corners of the patch. Because of the relatively short pot life of epoxy systems, the placing, consolidating, and finishing operations must be performed without delay.

(e) In final finishing, excess material should not be manipulated onto concrete adjacent to the patch because the carryover material is difficult to clean up. In finishing operations, proper surface smoothness must be achieved. The epoxy mixture tends to build up on the finishing tools, requiring frequent cleaning with an appropriate solvent. After each cleaning, the tool surfaces must be wiped free of excess solvent.

(f) The materials used in the two epoxy systems and the solvents used for cleanup do not ordinarily present a health hazard except to hypersensitive individuals. The materials may be handled safely if adequate precautionary measures are observed. Safety and health precautions for use with epoxies are given in TM 5-822-9, Repair of Rigid Pavements Using Epoxy-Resin Grout, Mortars, and Concrete.

(2) Latex-modified overlays. Styrene-butadiene is the most commonly used latex for concrete overlays (Clear and Chollar 1978).

(a) The materials and mixing procedures for latex-modified mortar and concrete are similar to those for conventional concrete portland-cement mortar and concrete. Latexes in a dispersed form are simply used in larger quantities in comparison to other chemical admixtures. The construction procedure for latex-modified concrete overlays parallels that for conventional concrete overlays except that (1) the mixing equipment

must have a means of storing and dispensing the latex into the mixture, (2) the latex-modified concrete has a high slump (typically  $125 \pm 25$  mm ( $5 \pm 1$  in.)) and is not air-entrained, and (3) a combination of wet and dry curing is required.

(b) Latex-modified concrete has been produced almost exclusively in mobile, continuous mixers fitted with an additional storage tank for the latex. The latex modifier should always be maintained between 7 and 30 °C (45 and 85 °F). Maintaining the correct temperature may present serious difficulties, especially during the summer months, and may necessitate night placing operations. Hot weather also causes rapid drying of the latex-modified concrete, which promotes shrinkage cracks.

(c) The bond coat consisting of the mortar fraction of the latex-modified concrete is usually produced directly from the continuous mixer by eliminating the coarse aggregate from the mixture. The slurry is broomed into the concrete surface.

(d) Placing operations are straightforward. Finishing machines with conventional vibratory or oscillating screeds may be used, though a rotating cylindrical drum is preferred. Hand finishing is comparable to conventional concrete overlays.

(e) Wet burlap must be applied to the concrete as soon as it will be supported without damage. After 1 to 2 days, the burlap is removed and the overlay should be permitted to air dry for a period of not less than 72 hr. The initial period of wet curing is necessary for the hydration of the portland cement and to prevent the formation of shrinkage cracks; the period of air drying is necessary to permit the latex to dry out and the latex to coalesce and form a continuous film. The film formation within the concrete gives the concrete good bond, flexural strength, and low permeability. The film-forming properties of the latex are temperature sensitive and develop very slowly at temperatures lower than 13 °C (55 °F). Placing and curing should not be done at temperatures lower than 7 °C (45 °F).

(f) See ACI 548.4 for a standard specification for latex-modified concrete overlays. Case histories of repairs with polymer-modified concrete overlays are described by Campbell (1994).

## 6-17. Overlays (Portland-Cement)

*a. Description.* Overlays are simply layers of concrete (usually horizontal) placed over a properly prepared

existing concrete surface to restore a spalled or disintegrated surface or increase the load-carrying capacity of the underlying concrete. The overlay thickness typically ranges from 102 to 610 mm (4 to 24 in.), depending upon the purpose it is intended to serve. However, overlays as thin as 38 mm (1-1/2 in.) have been placed. For information on polymer-based overlays see Section 6-16.

### *b. Applications and limitations.*

(1) A portland-cement-concrete overlay may be suitable for a wide variety of applications, such as resurfacing spalled or cracked concrete surfaces on bridge decks or lock walls, increasing cover over reinforcing steel, or leveling floors or slabs. Other applications of overlays include repair of concrete surfaces which are damaged by abrasion-erosion and the repair of deteriorated pavements (TM 5-822-6).

(2) Portland-cement-concrete overlays should not be used in applications in which the original damage was caused by aggressive chemical attack that would be expected to act against the portland cement in the overlay. Bonded overlays should not be used in situations in which there is active cracking or structural movement since the existing cracks can be reflected through the overlay or the movement can induce cracks in the overlay; unbonded overlays should be used in these situations.

*c. Procedure.* The general procedure for applying overlays is as follows: removal of the existing deteriorated concrete; preparation of the concrete surface, including sand- or waterblasting the concrete surface and applying a bonding agent to the surface, if necessary; and placing, consolidating, and curing the overlay. Case histories of repairs with a variety of concrete overlays are described by Campbell (1994).

(1) The guidance given in Chapter 5 should be followed for removal of deteriorated concrete and for preparing the concrete surface. For a bonded overlay to perform properly, the surface to which it is to be bonded must be clean, dry, rough, and dust-free.

(2) The potential for cracking of restrained concrete overlays should be recognized. Any variations in concrete materials, mixture proportions, and construction practices that will minimize shrinkage or reduce concrete temperature differentials should be considered for bonded overlays. Reduced cracking in resurfacing of lock walls has been attributed to lower cement content, larger maximum size coarse aggregate, lower placing and curing temperatures, smaller volumes of placement, and close attention

to curing (Wickersham 1987). Preformed contraction joints 1.5 m (5 ft) on center have been effective in controlling cracking in vertical and horizontal overlays. The critical timing of saw cutting necessary for proper joint preparation is such that this procedure is not recommended for concrete overlays. Where structural considerations permit, an unbonded overlay may be used to minimize cracking caused by restrained contraction of the concrete overlay.

(3) Placing, consolidating, and curing of conventional concrete overlays should follow the guidance given in EM 1110 -2-2000.

### 6-18. Polymer Coatings

*a. Description.* Polymer coatings, if the right material for the job condition is selected and properly applied, can be an effective protective coating to help protect the concrete from abrasion, chemical attack, or freeze and thaw damage. Epoxy resins are widely used for concrete coatings. Other polymer coatings include polyester resins and polyurethane resins (ACI 503R and ACI 515.1R).

*b. Applications and limitations.*

(1) Epoxy resin is used as a protective coating because of its impermeability to water and resistance to chemical attack. It is important that any polymer coating be selected from material designed specifically for the intended application. Some formulations will adhere to damp surfaces and even underwater but many require a completely dry surface. Mixing and applying polymers below 16 °C (60 °F) and above 32 °C (89 °F) will require special caution and procedures. Special sharp sand must be broadcast on the fresh surface if foot traffic is expected on the finished surface. Because of their high exotherm and higher shrinkage values, a neat epoxy in thicker sections is likely to crack.

(2) Slab-on-grade, concrete walls with backfills, or any slab not completely protected from rainwater and subject to freezing and thawing should never receive a coating that will form a vapor barrier. Moisture passing through the subgrade, backfill, or from rain water can accumulate under the coating which will be disrupted by freezing and thawing.

*c. Procedure.* See applicable portions of Section 6-16.

### 6-19. Polymer Concrete/Mortar

*a. Description.* Polymer concrete (PC) is a composite material in which the aggregate is bound together in a dense matrix with a polymer binder (ACI 548.1R). A variety of polymers are being used; the best known and most widely used is epoxy resin (ACI 503R). Some of the other most widely used monomers for PC patching materials include unsaturated polyester resins, a styrene, MMA, and vinylesters. Polymer concrete is quicker setting, has good bond characteristics, good chemical resistance, and high tensile, flexural, and compressive strength compared to conventional concrete. Epoxy resins should meet the requirements of ASTM C 881 (CRD-C 595). The correct type, grade, and class to fit the job should be specified. REMR Technical Note CS-MR-7.1 (USAEWES 1985e) provides general information on eight different types of polymer systems and typical application in maintenance and repair of concrete structures.

*b. Applications and limitations.*

(1) Epoxy resins can be formulated for a wide range of physical and chemical properties. Some epoxies must be used on dry concrete while others are formulated for use on damp concrete and even underwater. Epoxy hardening is very temperature dependent, and epoxies resins are difficult to apply at temperatures lower than about 16 °C (60 °F). Below 10 °C (50 °F) artificial heating of the material and the substrate must be employed. It is important that epoxy resin or other polymers be selected from material designed specifically for the intended use. Thermosetting polymers, such as polyester and epoxy, exhibit shrinkage during hardening. The shrinkage can be reduced by increasing the amount of aggregate filler.

(2) Other polymers including acrylic polymers (MMA's, HMWM's) and polyesters are being used to make PC. A number of commercial companies now market acrylic-polymer concrete and polyester-polymer concrete used for patching concrete and for overlays. The polyester PC is more widely available because of moderate cost. Polyester resins are more sensitive to moisture than epoxy resins and must be applied on dry concrete.

*c. Procedure.* Epoxy resins should meet the requirements of ASTM C 881 (CRD-C 595), Type III. For procedures see Section 6-16.

## 6-20. Polymer Portland-Cement Concrete

*a. Description.* Polymer portland-cement concrete (PPCC) mixtures are normal portland-cement concrete mixtures to which a water-soluble or emulsified polymer has been added during the mixing process (ACI 548.1R). PPCC has at times been called polymer-modified concrete. The addition of a polymer to portland-cement concrete or mortar can improve strength and adhesive properties. Also, these materials have excellent resistance to damage by freezing and thawing, a high degree of permeability, and improved resistance to chemicals, abrasion, and impact. Latex polymers have been most widely used and accepted. They include styrene butadiene, acrylics, polyvinyl chlorides, and polyvinyl acetates.

*b. Applications and limitations.* PPCC has superior adhesive properties and can be used in thinner patches and overlays than conventional portland-cement concrete; however, they should not be featheredged. Properties of latexes used in concrete vary considerably so that care should be taken to choose the material best suited for job conditions. Polyvinyl acetates will reemulsify in water and should not be used if the repair will be in continuous contact with water. Ambient temperature can greatly effect the working life for many polymers. PPCC should not be placed at temperatures below 7 °C (45 °F).

*c. Procedures.* Mixing and handling procedures for PPCC are similar to those used for conventional concrete and mortar; however, curing is different. The film-forming feature of PPCC is such that 1 to 2 days of moist curing followed by air curing is usually sufficient (ACI 548.3R). See Ramakrishnan (1992) for construction practices and specifications for latex-modified concrete.

## 6-21. Polymer Impregnation

*a. Description.* Polymer impregnated concrete (PIC) is a portland-cement concrete that is subsequently polymerized (ACI 548.1R). This technique requires use of a monomer system, which is a liquid that consists of small organic molecules capable of combining to form a solid plastic. Monomers have varying degrees of volatility, toxicity, and flammability and do not mix with water. They are very fluid and will soak into dry concrete and fill the cracks. Monomer systems used for impregnation contain a catalyst or initiator and the basic monomer (or different isomers of the same monomer). The systems may also contain a cross-linking agent. When heated, the monomers join together, or polymerize to become a tough, strong, durable plastic, which in concrete greatly enhances a number of the properties of the concrete.

*b. Applications and limitations.* Polymer impregnation can be used for repair of cracks (ACI 224.1R). If a cracked concrete surface is dried, flooded with the monomer, and polymerized in place, the cracks will be filled and structurally repaired. However, if the cracks contain moisture, the monomer will not soak into the concrete and, consequently, the repair will be unsatisfactory. If a volatile monomer evaporates before polymerization, it will be ineffective. Polymer impregnation has not been used successfully to repair fine cracks. Use of this system requires experienced personnel and some special equipment.

*c. Procedure.* Badly fractured beams have been repaired with polymer impregnation by drying the fracture, temporarily encasing it in a watertight (monomer proof) band of sheet metal, soaking the fractures with a monomer, and polymerizing the monomer. Large voids or broken areas in compression zones can be filled with fine and coarse aggregate before flooding them with the monomer, providing a polymer-concrete repair. A detailed discussion of polymer impregnation is given in ACI 548.1R. See also the gravity soak procedure described in Section 6-10.

## 6-22. Polymer Injection

*a. Description.* Polymers commonly used to repair cracks or joints by injection may be generally categorized as either rigid or flexible systems. Epoxies are the most common rigid systems used for structural repair or “welding” of cracks to form a monolithic structure. Flexible polyurethane systems are most often used for stopping water flow and sealing active cracks. Cracks as narrow as 0.05 mm (0.002 in.) can be bonded by the injection of epoxy (ACI 224.1R). The technique generally consists of drilling holes at close intervals along the cracks, in some cases installing entry ports, and injecting the epoxy under pressure. Although the majority of the injection projects have been accomplished with high-pressure injection, some successful work has been done with low pressures.

*b. Applications and limitations.*

(1) Rigid repairs. Epoxy injection has been successfully used in the repair of cracks in buildings, bridges, dams, and other types of concrete structures. However, unless the crack is dormant (or the cause of cracking is removed, thereby making the crack dormant), cracking will probably recur, and structural repair by injection should not be used. With the exception of certain specialized epoxies, this technique is not applicable if the cracks are actively leaking and cannot be dried out. While moist

cracks can be injected, contaminants in the crack (including water) will reduce the effectiveness of the epoxy to structurally repair the crack. Epoxy injection can also be used in the repair of delaminations in bridge decks.

(2) Flexible repairs. If the cracks are active and it is desired to seal them while allowing continued movement at these locations, it is necessary to use a grout that allows the filled crack to act as a joint. This is accomplished by using a polymer which cures into a closed-cell foam. Water-activated polyurethane grouts, both hydrophobic and hydrophilic, are commonly used for sealing leaking cracks. Solomon and Jaques (1994) provide an excellent discussion of materials and methods for injecting leaking cracks. Applications of water-activated polyurethanes in repair of waterstop failures are discussed in Section 8-2. Also, see Section 6-11.

(3) Polymer injection generally requires a high degree of skill for satisfactory execution, and application of the technique may be limited by ambient temperature.

*c. High-pressure injection procedure.* The majority of injection projects are accomplished with high-pressure injection (350 KPa (50 psi) or higher). The general steps involved in epoxy injection are as follows (ACI 224.1R).

(1) Clean the cracks. The first step is to clean the cracks that have been contaminated. Oil, grease, dirt, or fine particles of concrete prevent epoxy penetration and bonding. Preferably, contamination should be removed by flushing with water or, if the crack is dry, some other specially effective solvent. The solvent is then blown out with compressed air, or adequate time is allowed for air drying.

(2) Seal the surfaces. Surface cracks should be sealed to keep the polymer from leaking out before it has gelled. Where the crack face cannot be reached but where there is backfill or where a slab-on-grade is being repaired, the backfill material or subbase material is often an adequate seal. A surface can be sealed by brushing an epoxy along the surface of the crack and allowing it to harden. If extremely high injection pressures are needed, the crack should be cut out to a depth of 13 mm (1/2 in.) and width of about 20 mm (3/4 in.) in a V-shape, filled with an epoxy, and struck off flush with the surface. If a permanent glossy appearance along the crack is objectionable and if high injection pressure is not required, a strippable plastic may be applied along the crack.

(3) Install the entry ports. Three methods are in general use:

(a) Drilled holes--fittings inserted. Historically, this method was the first to be used and is often used in conjunction with V-grooving of the cracks. The method entails drilling a hole into the crack, approximately 19 mm (3/4 in.) in diam and 13 to 25 mm (1/2 to 1 in.) below the apex of the V-grooved section, into which a fitting such as a pipe nipple or tire valve stem is bonded with an epoxy adhesive. A vacuum chuck and bit are useful in preventing the cracks from being plugged with drilling dust. Hydrostatic pressure tests showed that molded injection ports mounted within a drilled port hole can withstand pressures of 1.4 to 1.9 MPa (200 to 275 psi) before leaks begin to develop. In comparison, surface-mounted ports withstood pressures between 0.3 and 1.0 MPa (50 and 150 psi), depending on the type of port (Webster, Kukacka, and Elling 1990).

(b) Bonded flush fitting. When the cracks are not V-grooved, a method frequently used to provide an entry port is to bond a fitting flush with the concrete face over the crack. This flush fitting has a hat-like cross section with an opening at the top for the adhesive to enter.

(c) Interruption in seal. Another system of providing entry is to omit the seal from a portion of the crack. This method can be used when special gasket devices are available that cover the unsealed portion of the crack and allow injection of the adhesive directly into the crack without leaking.

(4) Mix the epoxy. Epoxy systems should conform to ASTM C 881 (CRD-C 595), Type I, low-viscosity grade. Mixing is done either by batch or continuous methods. In batch mixing, the adhesive components are premixed according to the manufacturer's instructions, usually with the use of a mechanical stirrer, such as a paint-mixing paddle. Care must be taken to mix only the amount of adhesive that can be used prior to commencement of gelling of the material. When the adhesive material begins to gel, its flow characteristics begin to change, and pressure injection becomes more and more difficult. In the continuous mixing system, the two liquid adhesive components pass through metering and driving pumps prior to passing through an automatic mixing head. The continuous mixing system allows the use of fast-setting adhesives that have a short working life.

(5) Inject the epoxy. Hydraulic pumps, paint pressure pots, or air actuated caulking guns can be used. The pressure used for injection must be carefully selected. Increased pressure often does little to accelerate the rate of injection. In fact, the use of excessive pressure can propagate the existing cracks, causing additional damage.

If the crack is vertical, the injection process should begin by pumping into the entry port at the lowest elevation until the epoxy level reaches the entry port above. The lower injection port is then capped, and the process is repeated at successively higher ports until the crack has been completely filled and all ports have been capped. For horizontal cracks, the injection should proceed from one end of the crack to the other in the same manner. The crack is full if the pressure can be maintained. If the pressure cannot be maintained, the epoxy is still flowing into unfilled portions or leaking out of the crack.

(6) Remove the surface seal. After the injected epoxy has cured, the surface seal should be removed by grinding or other means, as appropriate. Fittings and holes at entry ports should be painted with an epoxy patching compound.

*d. Alternate high-pressure procedure.* To develop alternatives to concrete removal and replacement in repair of mass concrete hydraulic structures, a study was initiated, as part of the REMR Research Program, to evaluate in situ repair procedures.

(1) Eight injection adhesives were experimentally evaluated to determine their effectiveness in the repair of air-dried and water-saturated cracked concrete. The adhesives were three epoxies, an emulsifiable polyester resin, furfuryl alcohol, a furan resin, a high-molecular-weight methacrylate, and a polyurethane. Because of their low bond strength to water-saturated concrete, the furan resin, furfuryl alcohol, and the polyurethane were not considered further as injection adhesives. The remaining adhesives were used to repair both air-dried and water-saturated concrete slabs by conventional injection. The most promising adhesive was a two-component, very low-viscosity epoxy system designed specifically for pressure injection repairs (Webster and Kukacka 1988).

(2) A field test was performed on a tainter gate pier stem at Dam 20, Mississippi River, to demonstrate, under actual field conditions, the procedures developed in the laboratory and to evaluate the effectiveness of the materials and equipment selected for use (Webster, Kukacka, and Elling 1989). Problem areas identified during the field test were addressed in development of a modified repair procedure. Modifications included a better method for attaching the injection ports to the concrete and drilling small-diameter holes into the concrete to facilitate epoxy penetration into the multiple, interconnecting cracks. The modified procedure was demonstrated at Dam 13 on the Mississippi River near Fulton, Illinois (Webster, Kukacka, and Elling 1990).

(3) The first step in this repair procedure is to clean the concrete surfaces by sandblasting. Next, injection holes are drilled. These holes, 13 mm in (1/2 in.) diam and 152 mm (6 in.) deep, are wet drilled to flush fines from the holes as they occur. After injection ports are installed, the entire surface of the repair area is sealed with epoxy. After the seal has cured, injection is begun.

(4) Visual examinations of cores taken after injection indicate that a crack network within 152 to 254 mm (6 to 10 in.) of the surface can be filled with epoxy. These examinations indicate that the special injection procedure works very well and laboratory tests substantiate this conclusion. For example, splitting tensile strengths of the repaired cores average more than twice that of the unrepaired cores and only 10 percent less than the strength of the uncracked concrete.

*e. Low-pressure injection.* Similar results are attainable with either low-pressure or high-pressure injection procedures. For example, results achieved through an injection pressure of 2 MPa (300 psi) for 3 min are reportedly duplicated at a pressure of only 0.03 MPa (5 psi) or less for a period of 1 hr, presuming a low-viscosity, long pot life resin is used (Trout 1994). Generally, anything that can be injected with high pressure can be injected with low pressure; it just takes longer, which accounts for the selection of high-pressure systems for most large projects. However, there are situations where low-pressure injection has distinct advantages.

(1) Low injection pressures allow the use of easily removable materials for sealing the surface of the crack, whereas high-pressure injection normally requires an epoxy seal and aggressive removal procedures. Seals that are easily removed minimize the potential for surface blemishes which is particularly important for architectural concrete. Some units designed specifically for low pressure use can maintain pressures of less than 0.01 MPa (1 psi) for delicate projects such as repair of murals and mosaics.

(2) Low-pressure systems are portable, easy to mobilize, require little support from other construction equipment, and their initial cost is about one-tenth the cost of a high-pressure system.

(3) Low-pressure injection is less hazardous, and the use of skilled or experienced labor is seldom critical. Typically, low-pressure systems use prebatched resin rather than metering dispensers. Once the resin is mixed, it is pressurized by air or springs within capsules, inflatable syringe-like devices, that are left in place until

the resin has gelled. The use of long pot life resins is essential for successful low-pressure injection: a gel time of 1 hr at 22 °C (72 °F) is recommended.

### 6-23. Precast Concrete

*a. Description.* Precast concrete is concrete cast elsewhere than its final position. The use of precast concrete in repair and replacement of structures has increased significantly in recent years and the trend is expected to continue. Compared with cast-in-place concrete, precasting offers a number of advantages including ease of construction, rapid construction, high quality, durability, and economy.

*b. Applications and limitations.* Typical applications of precast concrete in repair or replacement of civil works structures include navigation locks, dams, channels, floodwalls, levees, coastal structures, marine structures, bridges, culverts, tunnels, retaining walls, noise barriers, and highway pavement.

*c. Procedures.* Procedures for use of precast concrete in repair of a wide variety of structures are described in detail by McDonald and Curtis (in preparation). Case histories describing the use of precast concrete in repair of navigation lock walls are described in Section 8-1. Selected case histories of additional precast concrete applications are summarized in Section 8-5.

### 6-24. Preplaced-Aggregate Concrete

*a. Description.* Preplaced-aggregate concrete is produced by placing coarse aggregate in a form and then later injecting a portland-cement-sand grout, usually with admixtures, to fill the voids. As the grout is pumped into the forms, it will fill the voids, displacing any water, and form a concrete mass.

*b. Applications and limitations.* Typically, preplaced-aggregate concrete is used on large repair projects, particularly where underwater concrete placement is required or when conventional placing of concrete would be difficult. Typical applications have included underwater repair of stilling basins, bridge piers, abutments, and footings. Applications of preplaced-aggregate concrete in repair of navigation lock walls are described in Section 8-1. The advantages of using preplaced-aggregate concrete include low shrinkage because of the point-to-point aggregate contact, ability to displace water from forms as the grout is being placed, and the capability to work around a large number of blockouts in the placement area.

*c. Procedure.* Guidance on materials, mixture proportioning, and construction procedures for preplaced-aggregate concrete can be found in EM 1110-2-2000 and in ACI 304.1R.

### 6-25. Rapid-Hardening Cements

*a. Description.* Rapid-hardening cements are defined as those that can develop a minimum compressive strength of 20 MPa (3,000 psi) within 8 hr or less. The types of rapid-hardening cements and patching materials available and their properties are described in REMR Technical Note CS-MR-7.3 (USAEWES 1985g). A specification for prepackaged, dry, rapid-hardening materials is given in ASTM C 928.

*b. Applications and limitations.*

(1) Magnesium-phosphate cement (MPC). This material can attain a compressive strength of several thousand pounds per square inch in 1 hr. MPC is useful for cold-weather embedments and anchoring and for patching applications where a short downtime can justify the additional expense. Finishing must be performed quickly because of the rapid set. MPC must be used with non-calcareous aggregates. MPC has low, long-term shrinkage and is nonreactive to sulphates. MPC is air-cured in a manner similar to the way epoxy concrete is cured. A damp substrate will adversely affect hardening.

(2) High alumina cements (HAC). The 24-hr strength of HAC is approximately equivalent to the 28-day strength of portland-cement concrete. The initial set however is reported to be up to 3 hr, which may be beneficial for transportation of the mixed concrete. HAC is more stable at high temperature than portland cement, providing aggregates that resist the high temperatures are used. A disadvantage is that when high alumina cement is subjected to in-service conditions of high humidity and elevated temperatures greater than 20 °C (68 °F) there is a “conversion reaction” which can cause a drastic strength loss (Mailvaganam 1992).

(3) Regulated-set portland cement. The initial set time is 15-20 min, but the set may be retarded by the use of citric acid. Regulated-set portland cement is not recommended for use in concrete exposed to sulphate soils or water.

(4) Gypsum cements. Gypsum cements are fast-setting and can obtain compressive strengths of as much as 21 m MPa (3,000 psi) in 30 min. For the most part, however, they are not as durable as portland-cement

concrete. They abrade easily, are not as frost resistant, and may be affected by fuel or solvent spills.

(5) Special blended cements. There are many different types of blended cements available. These materials generally have very high-early strengths, and setting times may be adjusted so that they may be transported by ready-mix truck.

(6) Packaged patching materials. There are numerous rapid-hardening patching materials available from different suppliers. Many are excellent materials for a variety of uses, although the claims of certain attributes by some suppliers have not been borne out by testing. ASTM C 928 is a specification that can be used for these materials; however, this specification does not provide requirements for bond strength, for freeze-thaw durability, for sulphate exposure or alkali reactivity. These materials should be used only when a service record for the proposed material, in the same environment, is available or when government testing is performed.

*c. Procedure.* These materials should be mixed and placed in accordance with the suppliers recommendations.

## 6-26. Roller-Compacted Concrete

*a. Description.* Roller-compacted concrete (RCC) is defined as “concrete compacted by roller compaction; concrete that, in its unhardened state, will support a roller while being compacted” (ACI 116R). Properties of hardened RCC are similar to those of conventionally placed concrete.

*b. Applications and limitations.* RCC should be considered where no-slump concrete can be transported,

placed, and compacted with earth and rock-fill construction equipment. Ideal RCC projects will involve large placement areas, little or no reinforcement or embedded metals, or other discontinuities such as piles.

(1) The primary applications of RCC within the Corps of Engineers have been in new construction of dams and pavement. Meanwhile, RCC has been so successful for repair of non-Corps dams that the number of dam repair projects now exceeds the number of new RCC dams. The primary advantages of RCC are low cost (25 to 50 percent less than conventionally placed concrete) and rapid construction.

(2) RCC has been used to strengthen and improve the stability of existing dams, to repair damaged overflow structures, to protect embankment dams during overtopping, and to raise the crest on existing dams. Selected applications of RCC in repair of a variety of structures are summarized in Section 8-8.

*c. Procedures.* Guidance on the use of RCC is given in EM 1110-2-2006 and ACI 207.5R.

## 6-27. Routing and Sealing

*a. Description.* This method involves enlarging the crack along its exposed face and filling and sealing it with a suitable material (Figure 6-10). The routing operation may be omitted but at some sacrifice in the permanence of the repair. This is the simplest and most common method for sealing dormant cracks.

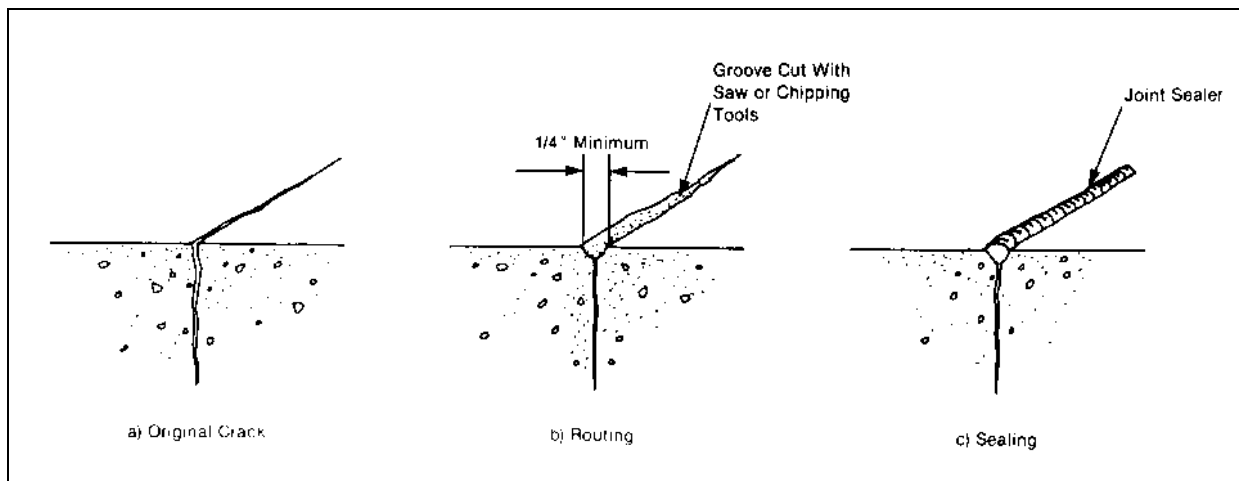

Figure 6-10. Repair of crack by routing and sealing



*b. Applications and limitations.* This method can be used on cracks that are dormant and of no structural significance. It is applicable to sealing both fine pattern cracks and large isolated defects. It will not be effective in repair of active cracks or cracks subject to significant hydrostatic pressure. However, some reduction in flow may be obtained when this method is used to seal the pressure face of cracks subject to hydrostatic pressure.

*c. Procedure.*

(1) The routing operation consists of following along the crack with a concrete saw or with hand or pneumatic tools and opening the crack sufficiently to receive the sealant. A minimum surface width of 6 mm (1/4 in.) is desirable since smaller openings are difficult to fill. The surfaces of the routed joint should be cleaned and permitted to dry before sealing.

(2) The purpose of the sealant is to prevent water from reaching the reinforcing steel, hydrostatic pressure from developing within the joint, the concrete surface from staining, or moisture problems on the far side of the member from developing. The sealant may be any of several materials, depending on how tight or permanent a seal is desired. Epoxy compounds are often used. Hot-poured joint sealant works very well when thorough watertightness of the joint is not required and appearance is not important. Urethanes, which remain flexible through large temperature variations, have been used successfully in cracks up to 19 mm (3/4 in.) in width and of considerable depth. There are many commercial products, and the manufacturers should be consulted to ascertain the type and grade most applicable to the specific purpose and condition of exposure. The Repair Materials Database (Section 4-5) contains information on a variety of crack repair materials. The method of placing the sealant depends on the material to be used, and the techniques recommended in ACI 504R should be followed.

## 6-28. Shotcrete

*a. Description.* Shotcrete is mortar pneumatically projected at high velocity onto a surface. Shotcrete can contain coarse aggregate, fibers, and admixtures. Properly applied shotcrete is a structurally adequate and durable repair material that is capable of excellent bond with existing concrete or other construction materials (ACI 506R).

*b. Applications and limitations.* Shotcrete has been used to repair deteriorated concrete bridges, buildings,

lock walls, dams, and other hydraulic structures. The performance of shotcrete repair has generally been good. However, there are some instances of poor performance. Major causes of poor performance include inadequate preparation of the old surface and poor application techniques by inexperienced personnel. Satisfactory shotcrete repair is contingent upon proper surface treatment of old surfaces to which the shotcrete is being applied. In a repair project where thin repair sections (less than 150 mm (6 in.) deep) and large surface areas with irregular contours are involved, shotcrete is generally more economical than conventional concrete because of the saving in forming costs. One of the problems in the shotcrete repair is overrun in estimated quantities. These overruns are usually related to underestimating the quantity of deteriorated concrete to be removed. Estimation errors can be minimized by a thorough condition survey as close as possible to the time that the repair work is to be executed. Most shotcrete mixtures have a high cement and therefore a greater potential for drying shrinkage cracking compared to conventional concrete (ACI 506R). Also, the overall quality is sensitive to the quality of workmanship. Problems associated with shotcrete repairs on nonair-entrained concrete are discussed in Section 8-1b.

*c. Procedure.* Guidance on the selection, proportioning, and application of shotcrete is given in EM 1110-2-2005. In addition, a small hand-held funnel gun was developed by the U.S. Army Engineer Division, Missouri River (1974), for pneumatic application of portland-cement mortar. The gun (Figure 6-11) is easily assembled from readily available material, has only a few critical dimensions, and can be operated by personnel without extensive training. The gun has been used successfully for application of mortar in small, shallow repairs on vertical and overhead surfaces.

## 6-29. Shrinkage-Compensating Concrete

*a. Description.* Shrinkage-compensating concrete is an expansive cement concrete which is used to minimize cracking caused by drying shrinkage in concrete slabs, pavements, and structures. Type K, Type M, or Type S expansive portland cements is used to produce shrinkage-compensating concrete. Shrinkage-compensating concrete will increase in volume after setting and during hardening. When properly restrained by reinforcement, expansion will induce tension in the reinforcement and compression in the concrete. On subsequent drying, the shrinkage so produced, instead of causing tensile cracking merely relieves the strains caused by the initial expansion (Figure 6-12).

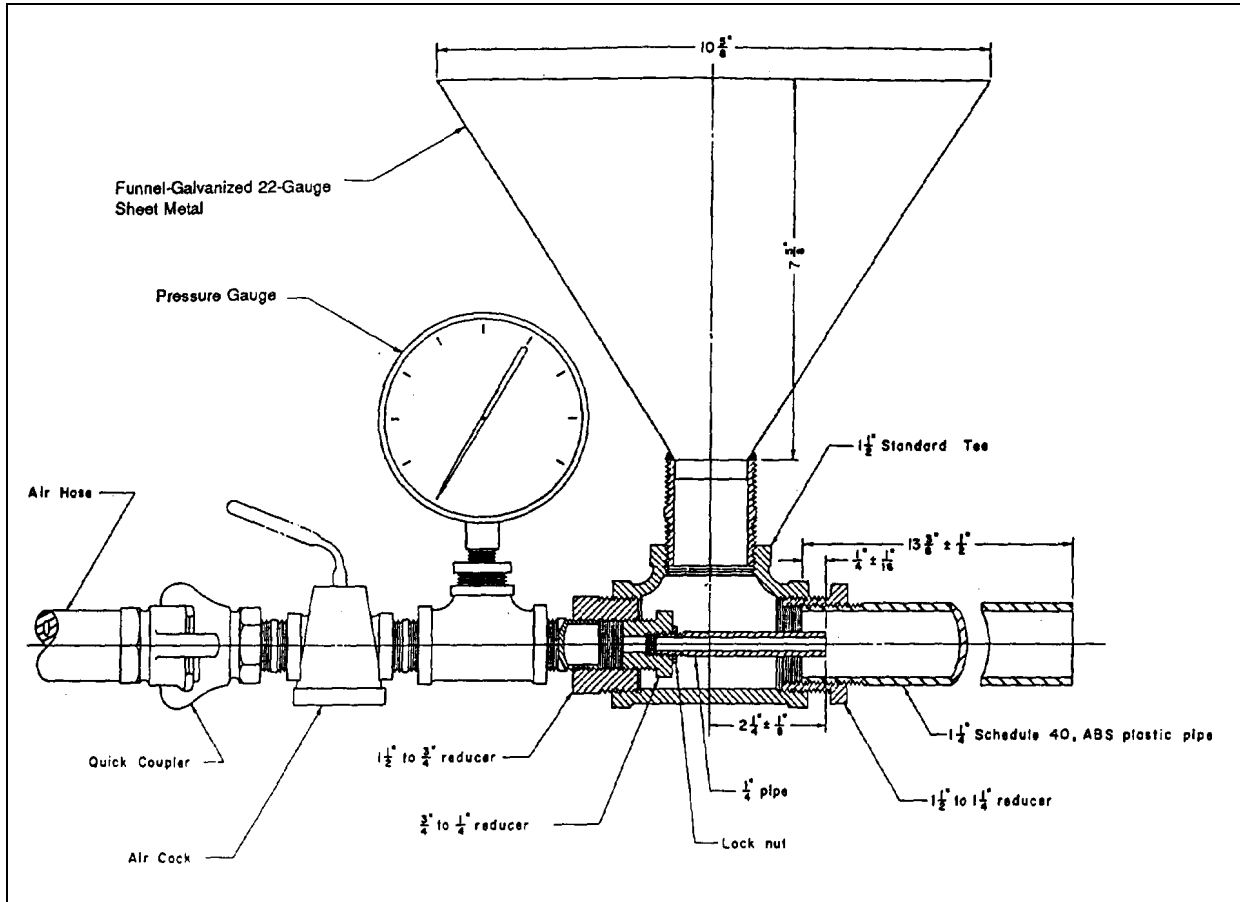

Figure 6-11. Mortar gun for concrete repair (U.S. Army Engineer Division, Missouri River 1974)

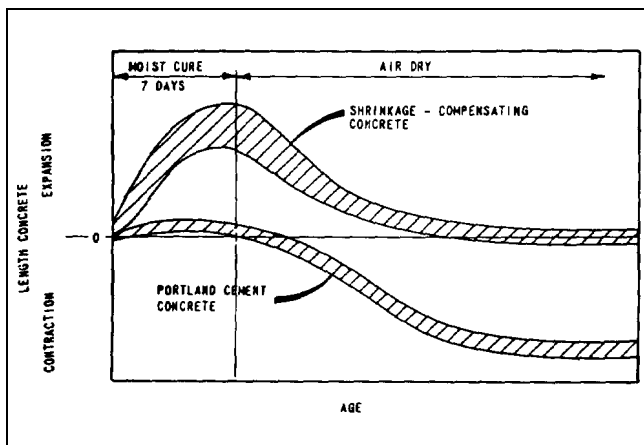

Figure 6-12. Typical length change characteristics of shrinkage-compensating and portland-cement concretes (ACI 223)

b. *Applications and limitations.* Shrinkage-compensating concrete may be used as bonded or

unbonded topping over a deteriorated or cracked concrete slab. The proper amount of internal reinforcement must be provided to develop shrinkage compensation. Early curing and proper curing are very important. Some shrinkage-compensating concrete mixtures will show early stiffening and a loss of workability. It is important to maintain close control over the amount of added mixture water so that the maximum w/c is not exceeded. Some ASTM C 494, Types A, D, F and G admixtures are not compatible with shrinkage-compensating cements. Larger distances may be used between contraction joints. For exposed areas, a maximum of 31 m (100 ft) is recommended. For areas protected from extreme fluctuations in temperature and moisture, joint spacing of 46 to 60 m (150 to 200 ft) have been used.

c. *Procedures.* Construction with shrinkage-compensating concrete generally follows the precepts for conventional portland-cement concrete. An excellent reference for design using shrinkage-compensating concrete is ACI 223.

### 6-30. Silica-Fume Concrete

*a. Description.* Silica fume, a by-product of silicon or ferrosilicon production, is a very fine powder with a medium to dark gray color. The spherical silica-fume particles are typically about 100 times smaller than portland-cement grains. The resulting high surface area is reflected in an increased water demand which can be overcome with a WRA or HRWRA. Silica fume is available in several forms: loose powder, densified powder, slurry, and, in some areas, as a blended portland-silica-fume cement. Silica fume is generally proportioned as an addition, by mass, to the cementitious materials and not as a substitution for any of these materials. The optimum silica-fume content ranges from about 5 to 15 percent by mass of cement. When properly used, silica fume can enhance certain properties of both fresh and hardened concrete, including cohesiveness, strength, and durability. Apparently, concretes benefit from both the pozzolanic properties of silica fume and the extremely small particle size. ACI 226 (1987) provides a detailed discussion on the use of silica fume in concrete.

*b. Applications and limitations.* The use of silica fume as a pozzolan in concrete produced in the United States has increased in recent years. Silica-fume concrete is appropriate for concrete applications which require very high strength, high abrasion-erosion resistance, very low permeability, or where very cohesive mixtures are needed to avoid segregation (EM 1110-2-2000). Silica-fume concrete should be considered for repair of structures subjected to abrasion-erosion damage, particularly in those areas where locally available aggregate might not otherwise be acceptable.

(1) Silica-fume concrete has been successfully used by the Corps of Engineers in repair of abrasion-erosion damaged concrete in stilling basins (Section 8-3d) and channels (Holland and Gutschow 1987). Although the placements generally went well, the silica-fume concrete overlay used to repair the Kinzua Dam stilling basin exhibited extensive cracking. However, these fine cracks have not adversely affected the performance of the repair.

(2) Concrete materials and mixture proportions similar to those used in the stilling basin repair were later used in laboratory tests to determine those properties of silica-fume concrete which might affect cracking (McDonald 1991). None of the material properties, with the possible exception of autogenous volume change, indicated that silica-fume concrete should be significantly more susceptible to cracking as a result of restrained contraction than conventional concrete. In fact, some

material properties, particularly ultimate tensile strain capacity, would indicate that silica-fume concrete should have a reduced potential for cracking.

*c. Procedure.* Silica-fume concrete requires no significant changes from normal transporting, placing, and consolidating practices. However, special considerations in finishing and curing practices may be required as discussed in EM 1110-2-2000. The potential for cracking of restrained concrete overlays, with or without silica fume, should be recognized. Any variations in concrete materials, mixture proportions, and construction practices that will minimize shrinkage or reduce concrete temperature differentials should be considered. Where structural considerations permit, a bond breaker at the interface between the replacement and existing concrete is recommended.

### 6-31. Slabjacking

*a. Description.* Slabjacking is a repair process in which holes are drilled in an existing concrete slab and a cementitious grout is injected to fill any voids and raise the slab as necessary. This process is also known as mudjacking.

*b. Applications and limitations.* Slabjacking is applicable to any situation in which a slab or other concrete section or grade needs to be repositioned. Slabjacking should be considered as an alternative to removal and replacement with conventional concrete. Reported applications include sidewalks, pavement slabs, water tanks, and swimming pools. This process has also been used to fill voids behind and under concrete structures; in such applications, it is simply a variation of portland-cement grouting.

*c. Procedure.* Information on procedures, materials, and equipment for slabjacking can be found in EM 1110-2-3506 and Meyers 1994.

### 6-32. Stitching

*a. Description.* This method involves drilling holes on both sides of the crack and grouting in stitching dogs (U-shaped metal units with short legs) that span the crack (Johnson 1965) (Figure 6-13).

*b. Applications and limitations.* Stitching may be used when tensile strength must be reestablished across major cracks. Stitching a crack tends to stiffen the structure, and the stiffening may accentuate the overall structural restraint, causing the concrete to crack elsewhere. Therefore, it may be necessary to strengthen the adjacent

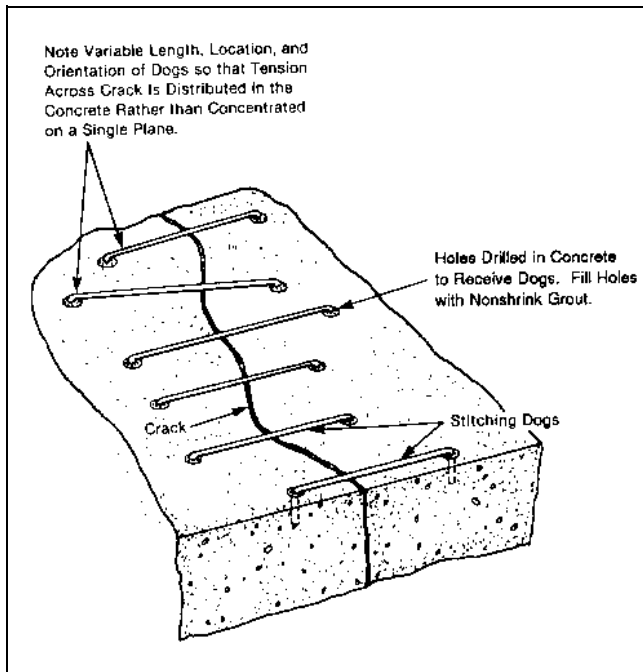

**Figure 6-13. Repair of a crack by stitching**

section with external reinforcement embedded in a suitable overlay.

*c. Procedure.*

(1) The stitching procedure consists of drilling holes on both sides of the crack, cleaning the holes, and anchoring the legs of the dogs in the holes, with either a non-shrink grout or an epoxy-resin-based bonding system. The stitching dogs should be variable in length and orientation or both, and they should be located so that the tension transmitted across the crack is not applied to a single plane within the section but is spread over an area.

(2) Spacing of the stitching dogs should be reduced at the end of cracks. In addition, consideration should be given to drilling a hole at each end of the crack to blunt it and relieve the concentration of stress.

(3) Where possible, both sides of the concrete section should be stitched so that further movement of the structure will not pry or bend the dogs. In bending members, it is possible to stitch one side of the crack only. Stitching should be done on the tension face, where movement is occurring. If the member is in a state of axial tension, then the dogs must be placed symmetrically, even if excavation or demolition is required to gain access to opposite sides of the section.

(4) Stitching will not close a crack but can prevent it from propagating further. Where there is a water problem, the crack should be made watertight as well as stitched to protect the dogs from corrosion. This repair should be completed before stitching begins. In the case of active cracks, the flexible sealing method (Section 6-9) may be used in conjunction with the stitching techniques.

(5) The dogs are relatively thin and long and cannot take much compressive force. Accordingly, if there is a tendency for the crack to close as well as to open, the dogs must be stiffened and strengthened, for example, by encasement in an overlay.

### 6-33. Underwater Concrete Placement

*a. Description.* Underwater concrete placement is simply placing fresh concrete underwater with a number of well recognized techniques and precautions to ensure the integrity of the concrete in place. Concrete is typically placed underwater by use of a tremie or a pump. The quality of cast-in-place concrete can be enhanced by the addition of an antiwashout admixture which increases the cohesiveness of the concrete. The special case in which the concrete is actually manufactured underwater, the preplaced-aggregate technique, is described in Section 6-24. Flat and durable concrete surfaces with in-place strengths and densities essentially the same as those of concrete cast and consolidated above water can be obtained with proper mixture proportioning and underwater placement procedures.

*b. Applicability and limitations.*

(1) Placing concrete underwater is a suitable repair method for filling voids around and under concrete structures. Voids ranging from a few cubic yards to thousands of cubic yards have been filled with tremie concrete. Concrete pumped underwater or placed by tremie has also been used to repair abrasion-erosion damage on several structures (McDonald 1980). Another specialized use of concrete placed underwater is in the construction of a positive cutoff wall through an earthfill dam. This process is discussed in Section 8-4.

(2) There are two significant limitations on the use of concrete placed underwater. First, the flow of water through the placement site should be minimized while the concrete is being placed and is gaining enough strength to resist being washed out of place or segregated. One approach that may be used to protect small areas is to use top form plates under which concrete may be pumped. The designer, contractor, and inspectors must all be

thoroughly familiar with underwater placements. Placing concrete underwater is not a procedure that all contractors and inspectors are routinely familiar with since it is not done as frequently as other placement techniques. The only way to prevent problems and to ensure a successful placement is to review, in detail, all aspects of the placement (concrete proportions, placing equipment, placing procedures, and inspection plans) well before commencing the placement.

*c. Procedures.* Guidance on proportioning concrete mixtures for underwater placement is given in EM 1110-2-2000. ACI 304R provides additional information on concrete placed underwater. Underwater repair of concrete is discussed in Section 8-6.

## Chapter 7 Maintenance of Concrete

### 7-1. General

Preventing concrete deterioration is much easier and more economical than repairing deteriorated concrete. Preventing concrete deterioration should actually begin with the selection of proper materials, mixture proportions, and placement and curing procedures. If additional protection against deterioration is required, the need should be recognized and provided for during design of the structure. Of course, all potential hazards to concrete cannot always be predicted, and some well-engineered techniques and procedures may prove unsuccessful. Thus, there is generally a need for follow-up maintenance action. The primary types of maintenance for concrete include timely repair of cracks and spalls, cleaning of concrete to remove unsightly material, surface protection, and joint restoration. Materials and procedures for repair of concrete cracking and spalling have been described in previous chapters. Materials and procedures appropriate for cleaning and protecting concrete surfaces and joint maintenance are described in the following.

### 7-2. Cleaning

Stains seldom affect the service life of a structure, although they are often unsightly, especially on architectural concrete finishes. Some of the more common stains are iron rust, oil, grease, dirt, mildew, asphalt, efflorescence, soot, and graffiti. Stains often penetrate the exposed surface because concrete is porous and absorbent. Therefore, stains should be removed as soon as possible to prevent deeper migration into the concrete. Also, stains tend to bind more tightly to the concrete with time, and some undergo chemical changes that make removal more difficult. Almost all stains can be removed if the type of stain can be identified and the correct removal method is selected (REMR Technical Note CS-MR-4.4 (USAEWES 1985d)).

*a. Identification.* The first step in the removal process is to identify the stain and then select a cleaning agent and method accordingly. If the stain is impossible to identify, potential cleaning materials should be tested in an inconspicuous area in the following order: organic solvents, oxidizing bleaches, reducing bleaches, and acids.

*b. Stain removal.* Stains can be removed with several methods including brushing and washing, steam

cleaning, water blasting, abrasive blasting, flame cleaning, mechanical cleaning, and chemical cleaning (*Concrete Repair Digest* 1993). Since there is usually more than one method that can be used to remove a given stain, the advantages and limitations of each potential method should be considered in making a final selection.

#### (1) Removal methods.

(a) Water washing. A fine mist spray is recommended, as excessive water pressure can drive the stain farther into the concrete. Washing should be done from the top of the structure down. If the water alone is not cleaning the concrete, it can be used in conjunction with the following in the order listed: a soft brush, a mild soap, a stronger soap, ammonia, or vinegar.

(b) Steam cleaning. Steam is generally good for removing dirt and chewing gum; however, in most applications it is relatively expensive.

(c) Water blasting. Water blasting removes less surface material than sandblasting because no abrasive is used; however, a test section to determine the effect of this method on surface texture is recommended.

(d) Abrasive blasting. Abrasive blasting tends to remove some of the concrete resulting in a nonuniform surface. The nozzle should be held farther from the surface than normal in any kind of blasting to minimize abrasion.

(e) Flame cleaning. Flame cleaning will remove organic materials that do not respond to solvents. However, this method can cause scaling of the concrete surface and may produce objectionable fumes.

(f) Mechanical cleaning. Power tools (grinders, buffers, chisels, brushes) may be required to remove the more stubborn stains from concrete. These tools can damage thin sections or remove more concrete than is desirable. Chiselling or grinding can be an effective cleaning method provided a roughened or uneven surface is acceptable.

(g) Chemical cleaning. Organic solvents can usually be used with little dilution. Inorganic solvents such as ammonium hydroxide, sodium hypochlorite, and hydrogen peroxide can be purchased in ready-mixed solutions; other organic solvents can be purchased as solids and then mixed with water according to manufacturer's directions. It may be desirable to mix the solvent to be used with an

inert fine powder to form a poultice which is then troweled over the stain (REMR Technical Note CS-MR-4.4 (USAEWES 1985d)). Chemical cleaning is often the best way to remove stains because most chemicals do not alter the surface texture of the concrete nor do they require the equipment needed by mechanical methods. However, there are safety considerations: many chemicals are mild and safe if used with care, while others are toxic, flammable, or corrosive to concrete. Manufacturer's directions and recommendations for the protection of occupational health and safety should be carefully followed. Material Safety Data Sheets (MSDS) should be obtained from the manufacturers of such materials. In cases where the effects of a chemical substance on occupational health and safety are unknown, chemical substances should be treated as potentially hazardous or toxic materials.

(2) Removing specific stains. Detailed procedures for removing a variety of stains are described in REMR Technical Notes CS-MR-4.3 and 4.4 (USAEWES 1985c and d) and *Concrete Repair Digest* (1993). The procedures are summarized in the following paragraphs.

(a) Iron rust. If the stain is light or shallow, mop the surface with a solution of oxalic acid and water. Wait 2 or 3 hr, and then scrub the surface with stiff brushes while rinsing with clear water. If the stain is deep, prepare a poultice by mixing sodium citrate, glycerol, and diatomaceous earth or talc with water and trowel the poultice over the stain. If the stain remains when the poultice is removed after 2 or 3 days, repeat the process as necessary.

(b) Oil. If the oil is freshly spilled, soak it up with absorbent paper; do not wipe it up. Cover the stain with a dry powdered material such as portland cement, hydrated lime, cornmeal, or cat litter. Wait approximately 24 hr, then sweep it up. Scrub the remaining stain with scouring powder or a strong soap solution. If the stain is old, cover it with flannel soaked in a solution of equal parts acetone and amyl acetate. Cover the flannel with a pane of glass or a thin concrete slab for 10 to 15 min. Repeat if necessary. Rinse when the cleaning process is complete.

(c) Grease. Scrape the grease from the surface. Scrub with scouring powder, strong soap or detergent, or sodium orthophosphate. If the stain persists, make a stiff poultice with one of the chlorinated solvents. Repeat if necessary. Rinse.

(d) Dirt. Most dirt can be removed with plain water or with a soft brush and water containing a mild soap. If a stronger solution is necessary, use 19 parts water to 1 part hydrochloric acid. If the dirt contains a lot of oil, use the methods for removing lubricating oil. Also, steam cleaning is generally effective for removing dirt. If the dirt is clay, scrape off all that has hardened. Scrub the stain with hot water containing sodium orthophosphate.

(e) Mildew. Mix powdered detergent and sodium orthophosphate with commercial sodium hypochlorite solution and water. After applying the mixture, wait a few days and then scrub the area. Rinse with clear water. Caution: sodium hypochlorite solution bleaches colored clothing and may corrode metal.

(f) Asphalt. Chill molten asphalt with ice (in summer). Scrape or chip it off while it is brittle. Then scrub the area with abrasive powder and rinse thoroughly with water. Do not apply solvents to emulsified asphalt as they will carry the emulsions deeper into the concrete. Scrub with scouring powder and rinse with water. Use a poultice of diatomaceous earth or talc and a solvent to remove cutback asphalt. When the poultice has dried, brush it off. Repeat if necessary.

(g) Efflorescence. Most efflorescence can be removed soon after it forms by washing or by a scrub brush and water. After the efflorescence has begun to build up a deposit, it can be removed by light water blasting or light sandblasting and hosing with clean water. However, some salts become water insoluble shortly after reaching the atmosphere. Efflorescence from these salts can be removed with a dilute solution of hydrochloric or phosphoric acid. Since an acid solution may slightly change the appearance of concrete or masonry, entire walls should be treated to avoid blotching. Only a 1-to 2-percent solution should be used on integrally colored concrete; stronger solutions may etch the surface, revealing the aggregate and hence changing color and texture.

(h) Soot. Scrub the stain with water and scouring powder, powdered pumice, or grit. If this treatment does not remove the stain, swab the area with trichloroethylene and apply a bandage made of three or four layers of cotton material soaked in trichloroethylene. If the stain is on a horizontal surface, hold the bandage against the stain with concrete slabs or stones. If the surface is vertical, prop the bandage against the stain. Periodically, remove, wring out, resaturate, and replace the bandage. Several treatments may be needed. Note: trichloroethylene is

highly toxic and can react with fresh concrete, or other strong alkalis, to form dangerous gases. An alternative to the bandage is a poultice. Mix sodium hypochlorite (commercial household bleach is about 5 percent hypochlorite) or diluted Javelle water with talc or other fine material to make a paste. Spread the paste on the stain and allow it to dry thoroughly. Brush off the residue. Repeat the treatment if necessary. Note: sodium hypochlorite and Javelle water will bleach colored clothing and are corrosive to metals.

(i) Graffiti. Apply a proprietary cleaner that contains an alkali, a solvent, and detergent. After scrubbing the graffiti with a brush, leave the cleaner in place for the time indicated by the manufacturer. Rinse thoroughly. Avoid contact with skin. A less expensive, nonproprietary cleaner is dichloromethane, which can be washed off with water. The procedure is the same as with a proprietary cleaner.

c. *Environmental considerations.* In addition to the potentially adverse worker health and safety effects, improper handling and disposal of cleaning materials and their associated solvents may have adverse environmental effects. Reasonable caution should guide the use of cleaning activities involving the use of potentially hazardous and toxic chemical substances (REMR Technical Note EI-M-1.2 (USAEWES 1985h)). Manufacturer's directions and recommendations for the protection of environmental quality should be carefully followed. The MSDS should be consulted for detailed handling and disposal instructions. The MSDS also provides guidance on appropriate responses in the event of spills. In cases where the effects of a chemical substance on environmental quality are unknown, chemical substances should be treated as potentially hazardous or toxic materials. Residual cleaning solutions may be classified as a hazardous waste, requiring special disposal considerations. The MSDS will generally recommend that Federal, state, and local regulations be consulted prior to determining disposal requirements. Improper handling and disposal of waste materials may result in civil and criminal liability.

### 7-3. Surface Coatings and Sealing Compounds

Surface coatings and sealing compounds are applied to concrete for protection against chemical attack of surfaces by acids, alkalis, salt solutions, or a wide variety of organic chemicals. Coatings and sealers may also be used to reduce the amount of water penetration into concrete and as a decorative system for concrete. Thick filled coatings are occasionally used to protect concrete from physical damage. Before a protective coating or sealer is

used on concrete, it should be determined that the concrete actually needs protection. The cause and extent of the deterioration, the rate of attack, the condition of the concrete, and the environmental factors must all be considered in the selection of a coating or sealer. For example, application of an impermeable coating or overlay may, under certain conditions, trap moisture within the concrete, thereby doing more harm than good (Section 6-16). Information on the susceptibility of concrete to chemical attack and selection, installation, and inspection of surface barrier systems is provided by ACI 515.1R, Pinney (1991), Bean (1988), and Husbands and Causey (1990).

a. *Surface preparation.* Proper concrete surface preparation is the single most important step for successful application of a coating. The concrete surface must be sound, clean, and dry before the coating is applied. Surface contaminants such as oils, dirt, curing compounds, and efflorescence must be removed. After the contaminants are removed, any unsound surface concrete must be removed before the concrete is coated.

(1) The most common method for determining the soundness of a concrete surface is the pipe-cap pulloff test (ACI 503R). Other commercial pulloff equipment such as the DYNA tester is satisfactory. Oils and other deep surface contaminants may have to be removed by chemical or steam cleaning. Abrasive blasting, shotblasting, high-pressure water, mechanical scarifiers, and acid cleaning are the methods most often used to remove the unsound surface concrete as well as most contaminants. Acid etching should be used only when other methods of surface preparation are impractical.

(2) Materials used to repair substrate surface defects should be compatible with the coating to be used. A latex-modified mortar should not be used if the coating to be used is solvent based. If epoxy resins are used, they should be highly filled and the surfaces should be slightly abraded before the coating is applied. Most coatings require a dry surface. Poor adhesion of a coating can result if water vapor diffuses out to the concrete surfaces.

(3) Some ASTM Standard Practices and Test Methods which may be helpful in preparing and inspecting concrete surfaces for coatings are listed below:

- Standard Practice for Surface Cleaning Concrete for Coating, ASTM D 4258.
- Standard Practice for Abrading Concrete, ASTM D 4259.



- Standard Practice for Acid Etching Concrete, ASTM D 4260.
- Standard Practice for Surface Cleaning Concrete Unit Masonry for Coating, ASTM D 4261.
- Test Method for pH of Chemically Cleaned or Etched Concrete Surfaces, ASTM D 4262.
- Test Method for Indicating Moisture in Concrete by the Plastic Sheet Method, ASTM D 4263.

b. *Coatings.* Factors to be considered in selection of a coating include intended function of the coating, properties of the coating, application conditions, anticipated service conditions, and life cycle costs. Coating properties that may be important, depending on the specific application, include abrasion resistance, water or chemical resistance, flexibility, curing time, temperature range, and aesthetics. ACI 515.1R and NACE International Standard RP0591-91 (NACE 1991) provide information on generic types of coatings that are appropriate for various exposure conditions. Candidate coating systems should be thoroughly evaluated to ensure that they are appropriate for the intended function and meet other desired characteristics such as ease of application and aesthetics. A test patch applied to the intended substrate in an area where the coating will be subjected to anticipated service conditions is recommended.

(1) General considerations.

(a) Typically, coating thicknesses range from a few mils to 3 mm (125 mils) or more, depending on the purpose of the coating. Thin coatings (<1 mm (40 mils)) are normally used for dampproofing, mild chemical attack, and for decorative coatings. Thick coatings (>1mm (40 mils)) are used for waterproofing, as protection against severe chemical attack, and as protection from physical damage.

(b) Coatings with very low permeabilities may do more harm than good by increasing the level of moisture in concrete if water enters the concrete from the side not coated (Section 6-16). Some coatings do transmit water vapor (breath) and these should be selected if it is expected that water will enter from the uncoated side of the concrete.

(c) Most coatings will not bridge cracks in concrete, but there are some elastomer coatings (polyurethanes and

acrylics) that will bridge narrow cracks (<0.8 mm (<1/32-in)). Some thin polymer coatings (high-molecular-weight methacrylates and a few epoxy resins) are formulated to seal cracks in horizontal concrete structures by gravity.

(2) Characteristics of coatings. Characteristics of selected coatings for concrete that prevent attack from corrosive chemicals in the atmosphere and reduce moisture penetration are discussed in the following and summarized in Table 7-1 (NACE 1991).

(a) Silicones, siloxanes, and silanes are best used as water repellents. These materials are not designed to resist chemical attack or physical abuse.

(b) Cementitious coatings may be decorative products and are usually modified with latex for use in mild chemical exposure conditions. Certain inorganic silicate cements may be used to waterproof concrete from the positive or negative side.

(c) Thin film urethanes (up to 0.13 mm (5 mils) per coat) are used to seal concrete for nondusting, cleanability, graffiti resistance, and resistance to mild chemicals. They are used for dry interior exposures on walls and floors that have moderate physical abuse and for exterior weathering. Urethanes are available in two forms: aliphatic urethanes for color and gloss retention in exterior sunlight exposure and aromatic urethanes for exposures other than sunlight and UV light, or where ambering and chalking are acceptable.

(d) Epoxy polyesters are thin film coatings (up to 0.08 mm (3 mils) per coat) designed for color, nondusting, cleanability, and resistance to water for a brief period. They are used primarily for interior and exterior exposures on walls that experience little physical abuse.

(e) Latexes are coatings used for color, appearance, and cleanability. For exterior use, acrylic latexes provide improved color and gloss retention (vinyl latexes are not normally recommended because they tend to hydrolyze under high pH situations). Elastomeric formulations (e.g., acrylic, silicone), which provide waterproofing and crack bridging properties, are also available.

(f) Chlorinated rubbers are thin film coatings designed for color, nondusting, cleanability, and resistance to water and mild chemicals; chlorinated rubbers may chalk on exterior weathering exposures, unless modified.

**Table 7-1  
Guidance on Selection of Concrete Coatings to Prevent Chemical Attack and Reduce Moisture Penetration (NACE 1991)**

Coating	Water Repellency	Cleanability	Aesthetic	Concrete Dusting	Mild Chemical	Severe Chemical	Moderate Physical	Severe Physical
Silicones/Silanes/Siloxane	R	NR	NR	NR	NR	NR	NR	NR
Cementitious	R	NR	R	NR	NR	NR	NR	NR
Thin-Film Polyurethane	R	R	R	R	R	NR	R	NR
Epoxy Polyester	R	R	R	R	R	NR	NR	NR
Latex <sup>1</sup>	R	R	R	R	NR <sup>2</sup>	NR	NR <sup>2</sup>	NR
Chlorinated Rubber	R	R	R	R	R	NR	R	NR
Epoxy	R	R	R	R	R	R	R	NR
Epoxy Phenolic	R	R	R	R	R	R	R	R
Aggregate Filled Epoxy	R	R	R	R	R	R	R	R
Urethane Elastomers	R	R	R	R	R	R	R	R
Epoxy or Urethane Coal Tar	R	R	NR	R	R	R	R	R
Vinyl Ester/Polyester	R	R	NR	R	R	R	R	R

Note: Reprinted with permission from NACE International. The complete edition of NACE Standard RP0591-91 is available from NACE International, P. O. Box 218340, Houston, Texas 77218-8340, phone: 713/492-0535, fax: 713/492-8254.

R = Recommended  
NR = Not Recommended

<sup>1</sup> Excluding vinyl latices

<sup>2</sup> Certain latices may be suitable for service

NOTE: The recommendations provided are general. Candidate coating systems must be thoroughly evaluated to ensure that they are appropriate for the intended service conditions and meet other desired characteristics. The above list is not necessarily all-inclusive.

(g) Epoxies are two component products that are available in thin film (less than 0.25 mm (10 mils)) and thick film (0.25 to 1.27 mm (10 to 50 mils)) coatings. Epoxies have excellent adhesion to dry concrete, and epoxies have the ability to seal porous concrete and bug holes. Epoxies also exhibit good chemical resistance, hardness, and abrasion resistance. Epoxies are typically used for interior chemical and physical abuse conditions, because they tend to chalk and fade in atmospheric and sunlight exposure. Epoxy formulations that develop good adhesion to wet surfaces are also available.

(h) Epoxy phenolics are two component products similar to epoxies. They are phenolic modified to improve their chemical resistance. They are normally used for severe chemical environments and as floor coatings.

(i) Aggregate-filled epoxies are thick film coatings (3.18 mm (125 mils) or more thickness) that are usually applied by spray, trowel, or aggregate broadcast methods. Normally used in areas of severe physical abuse, these epoxies are still resistant to mild and severe chemicals. They are excellent floor coatings for areas of severe physical abuse. Floor toppings can be made aesthetically pleasing through selection of the appropriate color and type of aggregate.

(j) Thick film elastomers (up to 3.18 mm (125 mils)), such as urethane (ASTM D 16 Type V) and polysulfide, are normally applied by spray, trowel, or self-leveling methods. Normally used in areas of severe physical abuse that require a flexible coating, the rubber-like film displays excellent resistance to impact damage and the ability to bridge hairline cracks in concrete.

(k) Epoxy- or urethane-coal tars are moderately thick coatings (0.38 to 0.76 mm (15 to 30 mils)) with excellent water and good chemical resistance that are normally applied with a sprayer. The black color may restrict their usage for aesthetic reasons.

(l) Vinylesters and polyesters are moderately thick coatings (0.76 to 1.27 mm (30 to 50 mils)) with excellent resistance to acids and strong oxidizers that are applied by spray or trowel. Thicker films may be obtained with silica floor fillers and reinforcing fabric or mat.

(m) Coatings, such as inorganic silicate cementitious products, sulphur concrete, polysulfide elastomers, epoxy polysulfides, and others, also offer protection to concrete exposed to atmospheric and aggressive environments such as secondary containment structures.

### (3) Application.

(a) The manufacturer's recommended application rate and method of application should be followed when a coating is applied to concrete. The surface profile and porosity will have an effect on the application rate. A test patch is useful in determining the surface preparation, application rate, and appearance of a particular concrete coating.

(b) The temperature of the concrete should be constant or dropping when some coatings are applied to avoid blisters or pin holes caused by the expansion of gases inside of the concrete. The temperature of the concrete should be above the dewpoint while the coating is curing to prevent water condensation on the coating.

*c. Sealers.* Sealers are thin, nonfilled liquids that penetrate or form a thin film (less than 0.13 mm (5 mils)) on concrete. Sealers are used for water repellency when there is no hydrostatic pressure, for dust control, and for reducing the amount of water soluble salts that enter into concrete. Penetrating sealers, such as the silanes and siloxanes, are recommended for areas subjected to traffic. Some sealers do not change the appearance of the concrete, but others may darken the surface. Some sealers are slightly volatile, and high winds and temperatures during application may affect their performance. Concrete sealers that have not been approved for the type of concrete masonry units (CMU) in service should not be used on CMU. Liquid surface treatments known as hardeners should be used only as emergency measures for treatment of deficiencies in hardened concrete floor slabs. They are not intended to provide additional wear resistance in new, well designed, well constructed, and cured floors (ACI 302.1R).

Pfeifer and Scali (1981) have provided what is probably the most comprehensive report on the sealer properties that are relevant for bridge concrete. The basic findings of this study were confirmed in subsequent work by Kottke (1987) and Husbands and Causey (1990). A performance-based specification for concrete sealers on bridges was developed by Carter (1993).

## 7-4. Joint Maintenance

Little maintenance is required for buried sealants such as waterstops because they are not exposed to weathering and other deteriorating influences. Most field-molded sealants will, however, require periodic maintenance if an effective seal is to be maintained and deterioration of the

structure is to be avoided. The necessity for joint maintenance is determined by service conditions and by the type of material used.

Minor touchups of small gaps and soft or hard spots in field-molded sealants can usually be made with the same sealant. However, where the failure is extensive, it is usually necessary to remove the sealant and replace it. A sealant that has generally failed but has not come out of the sealing groove should be removed by hand tools or, on large projects, by routing or plowing with suitable

tools. To improve the shape factor, the sealant reservoir may be enlarged by sawing. After proper preparation has been made to ensure clean joint faces and additional measures designed to improve sealant performance, such as improvement of shape factor, provision of backup material, and possible selection of a better type of sealant, have been accomplished, the joint may be resealed. For additional information on joint sealant materials, joint design, and installation of sealants, see EM 1110-2-2102, and ACI 504R.